



*An Online PDH Course  
brought to you by  
CEDengineering.com*

## **Introduction to Aircraft Engines**

Course No: Q05-001

Credit: 5 PDH

---

Ahmad Hammouz, P.Eng., LEED AP

---



Continuing Education and Development, Inc.

P: (877) 322-5800

[info@cedengineering.com](mailto:info@cedengineering.com)

*This course was adapted from the Federal Aviation Administration, Publication No. FAA-H-8083-32B, “Chapter 1: Aircraft Engines”, which is in the public domain.*

## **General Requirements**

Aircraft require thrust to produce enough speed for the wings to provide lift or enough thrust to overcome the weight of the aircraft for vertical takeoff. For an aircraft to remain in level flight, thrust must be provided that is equal to and in the opposite direction of the aircraft drag. This thrust, or propulsive force, is provided by a suitable type of aircraft heat engine. All heat engines have in common the ability to convert heat energy into mechanical energy by the flow of some fluid mass (generally air) through the engine. In all cases, the heat energy is released at a point in the cycle where the working pressure is high relative to atmospheric pressure.

The propulsive force is obtained by the displacement of a working fluid (again, atmospheric air). This air is not necessarily the same air used within the engine. By displacing air in a direction opposite to that in which the aircraft is propelled, thrust can be developed. This is an application of Newton's third law of motion. It states that for every action there is an equal and opposite reaction. So, as air is being displaced to the rear of the aircraft the aircraft is moved forward by this principle. One misinterpretation of this principle is air is pushing against the air behind the aircraft making it move forward. This is not true. Rockets in space have no air to push against, yet, they can produce thrust by using Newton's third law. Atmospheric air is the principal fluid used for propulsion in every type of aircraft powerplant except the rocket, in which the total combustion gases are accelerated and displaced. The rocket must provide all the fuel and oxygen for combustion and does not depend on atmospheric air. A rocket carries its own oxidizer rather than using ambient air for combustion. It discharges the gaseous byproducts of combustion through the exhaust nozzle at an extremely high velocity (action) and it is propelled in the other direction (reaction).

The propellers of aircraft powered by reciprocating or turboprop engines accelerate a large mass of air at a relatively lower velocity by turning a propeller. The same amount of thrust can be generated by accelerating a small mass of air to a very high velocity. The working fluid (air) used for the propulsive force is a different quantity of air than that used within the engine to produce the mechanical energy to turn the propeller.

Turbojets, ramjets, and pulse jets are examples of engines that accelerate a smaller quantity of air through a large velocity change. They use the same working fluid for propulsive force that is used within the engine. One problem with these types of engines is the noise made by the high velocity air exiting the engine. The term turbojet was used to describe any gas turbine engine, but with the differences in gas turbines used in aircraft, this term is used to describe a type of gas turbine that passes all the gases through the core of the engine directly.

Turbojets, ramjets, and pulse jets have very little to no use in modern aircraft due to noise and fuel consumption. Small general aviation aircraft use mostly horizontally opposed reciprocating piston engines. While some aircraft still use radial reciprocating piston engines, their use is very limited. Many aircraft use a form of the gas turbine engine to produce power for thrust. These engines are normally the turboprop, turboshaft, turbofan, and a few turbojet engines. "Turbojet" is the former term for any turbine engine. Now that there are so many different types of turbine engines, the term used to describe most turbine engines is "gas turbine engine." All four of the previously mentioned engines belong to the gas turbine family.

All aircraft engines must meet certain general requirements of efficiency, economy, and reliability. Besides being economical in fuel consumption, an aircraft engine must be economical in the cost of original procurement and the cost of maintenance; and it must meet exacting requirements of efficiency and low weight-to-horsepower ratio. It must be capable of sustained high-power output with no sacrifice in reliability; it must also have the durability to operate for long periods of time between overhauls. It needs to be as compact as possible yet have easy accessibility for maintenance. It is required to be as vibration free as possible and be able to cover a wide range of power output at various speeds and altitudes.

These requirements dictate the use of ignition systems that deliver the firing impulse to the spark plugs at the proper time in all kinds of weather and under other adverse conditions. Engine fuel delivery systems provide metered fuel at the correct proportion of air-fuel ingested by the engine regardless of the attitude, altitude, or type of weather in which the engine is operated. The engine needs a type of oil system

that delivers oil under the proper pressure to lubricate and cool all of the operating parts of the engine when it is running. Also, it must have a system of damping units to damp out the vibrations of the engine when it is operating.

### Power & Weight

The useful output of all aircraft powerplants is thrust, the force which propels the aircraft. Since the reciprocating engine is rated in brake horsepower (bhp), the gas turbine engine is rated in thrust horsepower (thp):

$$\text{Thp} = \frac{\text{thrust} \times \text{aircraft speed (mph)}}{375 \text{ mile-pounds per hour}}$$

The value of 375 mile-pounds per hour is derived from the basic horsepower formula as follows:

$$\begin{aligned} 1 \text{ hp} &= 33,000 \text{ ft-lb per minute} \\ 33,000 \times 60 &= 1,980,000 \text{ ft-lb per hour} \\ \frac{1,980,000}{5,280 \text{ ft in a mile}} &= 375 \text{ mile-pounds per hour} \end{aligned}$$

One horsepower equals 33,000 ft-lb per minute or 375 mile-pounds per hour. Under static conditions, thrust is figured as equivalent to approximately 2.6 pounds per hour.

If a gas turbine is producing 4,000 pounds of thrust and the aircraft in which the engine is installed is traveling at 500 mph, the thp is:

$$\frac{4,000 \times 500}{375} = 5,333.33 \text{ thp}$$

It is necessary to calculate the horsepower for each speed of an aircraft, since the horsepower varies with speed. Therefore, it is not practical to try to rate or compare the output of a turbine engine on a horsepower basis. The aircraft engine operates at a relatively high percentage of its maximum power output throughout its service life. The aircraft engine is at full power output whenever a takeoff is made. It may hold this power for a period of time up to the limits set by the manufacturer. The engine is seldom held at a maximum power for more than 2 minutes, and usually not that long. Within a few seconds after lift-off, the power is reduced to a power that is used for climbing and that can be maintained for longer periods of time. After the aircraft has climbed to cruising altitude, the power of the engine(s) is further reduced to a cruise power

which can be maintained for the duration of the flight. If the weight of an engine per brake horsepower (called the specific weight of the engine) is decreased, the useful load that an aircraft can carry and the performance of the aircraft obviously are increased. Every excess pound of weight carried by an aircraft engine reduces its performance. Tremendous improvement in reducing the weight of the aircraft engine through improved design and metallurgy has resulted in reciprocating engines with a much improved power-to-weight ratio (specific weight).

### Fuel Economy

The basic parameter for describing the fuel economy of aircraft engines is usually specific fuel consumption. Specific fuel consumption for gas turbines is the fuel flow measured in (lb/hr) divided by thrust (lb), and for reciprocating engines the fuel flow (lb/hr) divided by brake horsepower. These are called thrust-specific fuel consumption and brake-specific fuel consumption, respectively. Equivalent specific fuel consumption is used for the turboprop engine and is the fuel flow in pounds per hour divided by a turboprop's equivalent shaft horsepower. Comparisons can be made between the various engines on a specific fuel consumption basis. At low speed, the reciprocating and turboprop engines have better economy than the pure turbojet or turbofan engines. However, at high speed, because of losses in propeller efficiency, the reciprocating or turboprop engine's efficiency becomes limited above 400 mph less than that of the turbofan.

### Durability & Reliability

Durability and reliability are usually considered identical factors since it is difficult to mention one without including the other. Simply put, reliability is measured as the mean time between failures, while durability is measured as the mean time between overhauls.

More specifically, an aircraft engine is reliable when it can perform at the specified ratings in widely varying flight attitudes and in extreme weather conditions. Standards of powerplant reliability are agreed upon by the Federal Aviation Administration (FAA), the engine manufacturer, and the airframe manufacturer. The engine manufacturer ensures the reliability of the product by design, research, and testing. Close control of manufacturing and assembly procedures is maintained, and each engine is tested before it leaves the factory.

Durability is the amount of engine life obtained while maintaining the desired reliability. The fact that an engine has successfully completed its type or proof test indicates that it can be operated in a normal manner over a long period before requiring overhaul. However, no definite time interval between overhauls is specified or implied in the engine

rating. The time between overhauls (TBO) varies with the operating conditions, such as engine temperatures, amount of time the engine is operated at high-power settings, and the maintenance received. Recommended TBOs are specified by the engine manufacturer.

Reliability and durability are built into the engine by the manufacturer, but the continued reliability of the engine is determined by the maintenance, overhaul, and operating personnel. Careful maintenance and overhaul methods, thorough periodical and preflight inspections, and strict observance of the operating limits established by the engine manufacturer make engine failure a rare occurrence.

### **Operating Flexibility**

Operating flexibility is the ability of an engine to run smoothly and give desired performance at all speeds from idling to full-power output. The aircraft engine must also function efficiently through all the variations in atmospheric conditions encountered in widespread operations.

### **Compactness**

To affect proper streamlining and balancing of an aircraft, the shape and size of the engine must be as compact as possible. In single-engine aircraft, the shape and size of the engine also affect the view of the pilot, making a smaller engine better from this standpoint, in addition to reducing the drag created by a large frontal area.

Weight limitations, naturally, are closely related to the compactness requirement. The more elongated and spread out an engine is, the more difficult it becomes to keep the specific weight within the allowable limits.

### **Powerplant Selection**

Engine specific weight and specific fuel consumption were discussed in the previous paragraphs, but for certain design requirements, the final powerplant selection may be based on factors other than those that can be discussed from an analytical point of view. For that reason, a general discussion of powerplant selection follows.

For aircraft whose cruising speed does not exceed 250 mph, the reciprocating engine is the usual choice of powerplant. When economy is required in the low speed range, the conventional reciprocating engine is chosen because of its excellent efficiency and relatively low cost. When high altitude performance is required, the turbo-supercharged reciprocating engine may be chosen because it is capable of maintaining rated power to a high altitude (above 30,000 feet). Gas turbine engines operate most economically at high altitudes. Although in most cases the gas turbine engine provides superior performance, the cost of gas turbine

engines is a limiting factor. In the range of cruising speed of 180 to 350 mph, the turboprop engine performs very well. It develops more power per pound of weight than does the reciprocating engine, thus allowing a greater fuel load or payload for engines of a given power. From 350 mph up to Mach .8–.9, turbofan engines are generally used for airline operations. Aircraft intended to operate at Mach 1 or higher are powered by pure turbojet engines/afterburning (augmented) engines, or low-bypass turbofan engines.

## **Types of Engines**

Aircraft engines can be classified by several methods. They can be classed by operating cycles, cylinder arrangement, or the method of thrust production. All are heat engines that convert fuel into heat energy that is converted to mechanical energy to produce thrust. Most of the current aircraft engines are of the internal combustion type because the combustion process takes place inside the engine. Aircraft engines come in many different types, such as gas turbine based, reciprocating piston, rotary, two or four cycle, spark ignition, diesel, and air or water cooled. Reciprocating and gas turbine engines also have subdivisions based on the type of cylinder arrangement (piston) and speed range (gas turbine).

Many types of reciprocating engines have been designed. However, manufacturers have developed some designs that are used more commonly than others and are, therefore, recognized as conventional. Reciprocating engines may be classified according to the cylinder arrangement (inline, V-type, radial, and opposed) or according to the method of cooling (liquid cooled or air cooled). Actually, all piston engines are cooled by transferring excess heat to the surrounding air. In air-cooled engines, this heat transfer is direct from the cylinders to the air. Therefore, it is necessary to provide thin metal fins on the cylinders of an air-cooled engine in order to have increased surface for sufficient heat transfer. Most reciprocating aircraft engines are air cooled although a few high powered engines use an efficient liquid-cooling system. In liquid-cooled engines, the heat is transferred from the cylinders to the coolant, which is then sent through tubing and cooled within a radiator placed in the airstream. The coolant radiator must be large enough to cool the liquid efficiently. The main problem with liquid cooling is the added weight of coolant, heat exchanger (radiator), and tubing to connect the components. Liquid cooled engines do allow high power to be obtained from the engine safely.

### **Inline Engines**

An inline engine generally has an even number of cylinders, although some three-cylinder engines have been constructed. This engine may be either liquid cooled or air cooled and has only one crank shaft, which is located either above or below the cylinders. If the engine is designed to operate with the

cylinders below the crankshaft, it is called an inverted engine.

The inline engine has a small frontal area and is better adapted to streamlining. When mounted with the cylinders in an inverted position, it offers the added advantages of a shorter landing gear and greater pilot visibility. With increase in engine size, the air cooled, inline type offers additional problems to provide proper cooling; therefore, this type of engine is confined to low- and medium-horsepower engines used in very old light aircraft.

### Opposed or O-Type Engines

The opposed-type engine has two banks of cylinders directly opposite each other with a crankshaft in the center. [Figure 1-1] The pistons of both cylinder banks are connected to the single crankshaft. Although the engine can be either liquid cooled or air cooled, the air-cooled version is used predominantly in aviation. It is generally mounted with the cylinders in a horizontal position. The opposed-type engine has a low weight-to-horsepower ratio, and its narrow silhouette makes it ideal for horizontal installation on the aircraft wings (twin engine applications). Another advantage is its low vibration characteristics.

### V-Type Engines

In V-type engines, the cylinders are arranged in two inline banks generally set 60° apart. Most of the engines have 12 cylinders, which are either liquid cooled or air cooled. The engines are designated by a V followed by a dash and the piston displacement in cubic inches. For example, V-1710. This type of engine was used mostly during the Second World War and its use is mostly limited to older aircraft.

### Radial Engines

The radial engine consists of a row, or rows, of cylinders arranged radially about a central crankcase. [Figure 1-2] This type of engine has proven to be very rugged and dependable. The number of cylinders which make up a row may be three,

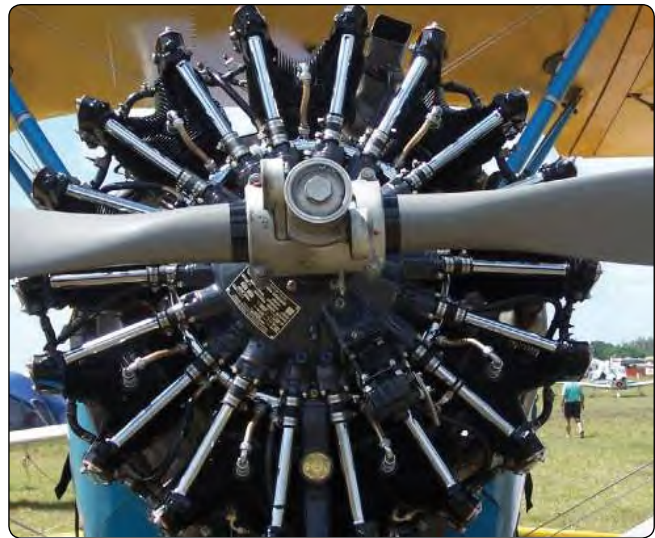

Figure 1-2. Radial engine.

five, seven, or nine. Some radial engines have two rows of seven or nine cylinders arranged radially about the crankcase, one in front of the other. These are called double-row radials. [Figure 1-3] One type of radial engine has four rows of cylinders with seven cylinders in each row for a total of 28 cylinders. Radial engines are still used in some older cargo airplanes, war birds, and crop spray airplanes. Although many of these engines still exist, their use is limited. The single-row, nine-cylinder radial engine is of relatively simple construction, having a one-piece nose and a two-section main crankcase. The larger twin-row engines are of slightly more complex construction than the single row engines. For example, the crankcase of the Wright R-3350 engine is composed of the crankcase front section, four crankcase main sections (front main, front center, rear center, and



Figure 1-1. A typical four-cylinder opposed engine.



Figure 1-3. Double row radials.

rear main), rear cam and tappet housing, supercharger front housing, supercharger rear housing, and supercharger rear housing cover. Pratt and Whitney engines of comparable size incorporate the same basic sections, although the construction and the nomenclature differ considerably.

## Reciprocating Engines

### Design & Construction

The basic major components of a reciprocating engine are the crankcase, cylinders, pistons, connecting rods, valves, valve-operating mechanism, and crankshaft. In the head of each cylinder are the valves and spark plugs. One of the valves is in a passage leading from the induction system; the other is in a passage leading to the exhaust system. Inside each cylinder is a movable piston connected to a crankshaft by a connecting rod. *Figure 1-4* illustrates the basic parts of a reciprocating engine.

### Crankcase Section

The foundation of an engine is the crankcase. It contains the bearings and bearing supports in which the crankshaft revolves. Besides supporting itself, the crankcase must provide a tight enclosure for the lubricating oil and must support various external and internal mechanisms of the

engine. It also provides support for attachment of the cylinder assemblies, and the powerplant to the aircraft. It must be sufficiently rigid and strong to prevent misalignment of the crankshaft and its bearings. Cast or forged aluminum alloy is generally used for crankcase construction because it is light and strong. The crankcase is subjected to many variations of mechanical loads and other forces. Since the cylinders are fastened to the crankcase, the tremendous forces placed on the cylinder tend to pull the cylinder off the crankcase. The unbalanced centrifugal and inertia forces of the crankshaft acting through the main bearings subject the crankcase to bending moments which change continuously in direction and magnitude. The crankcase must have sufficient stiffness to withstand these bending moments without major deflections. [*Figure 1-5*]

If the engine is equipped with a propeller reduction gear, the front or drive end is subjected to additional forces. In addition to the thrust forces developed by the propeller under high power output, there are severe centrifugal and gyroscopic forces applied to the crankcase due to sudden changes in the direction of flight, such as those occurring during maneuvers of the airplane. Gyroscopic forces are particularly severe when a heavy propeller is installed. To absorb centrifugal loads, a large centrifugal bearing is used in the nose section.

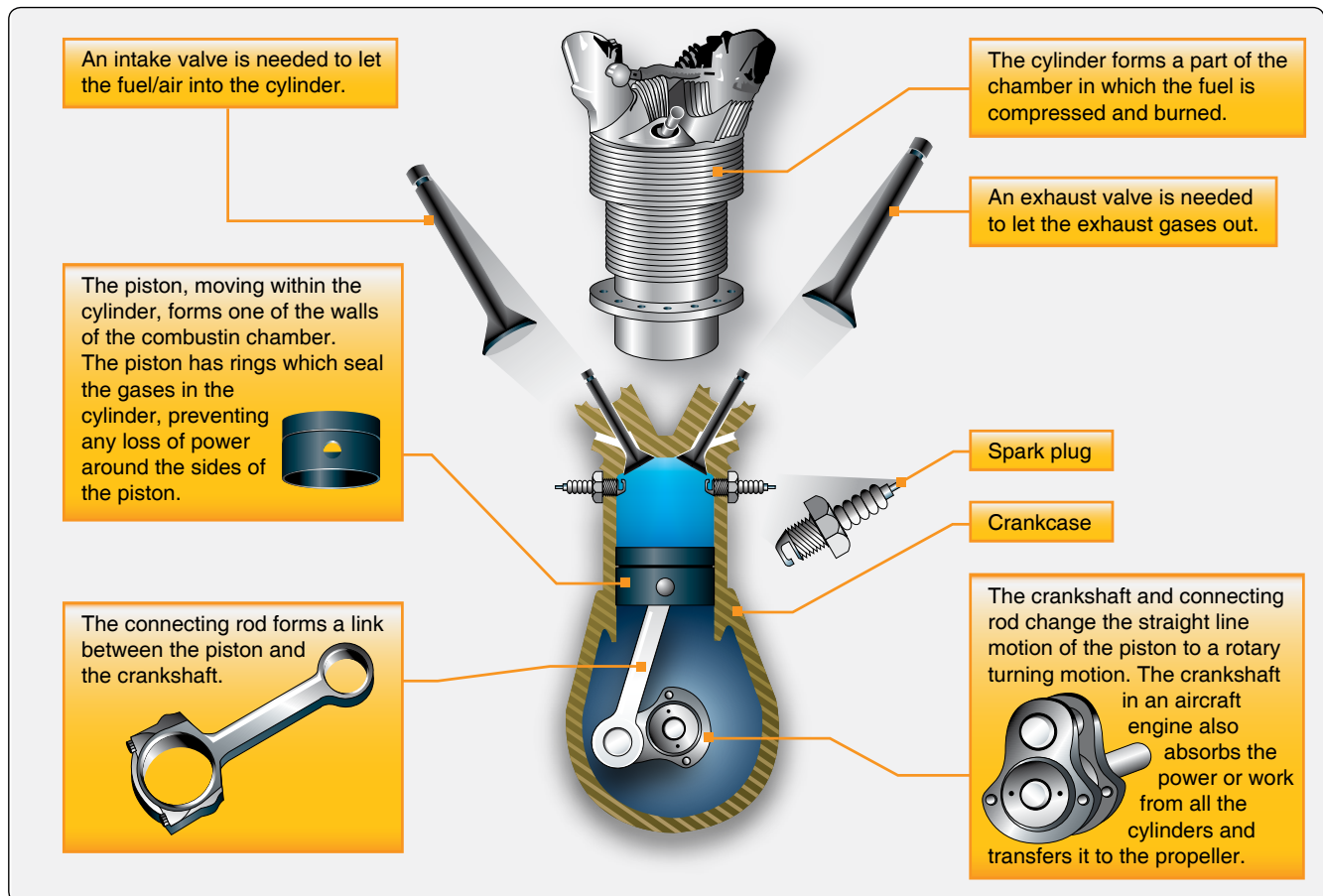

Figure 1-4. Basic parts of a reciprocating engine.



**Figure 1-5.** *The crankcase.*

The shape of the nose or front of the crankcase section varies considerably. In general, it is either tapered or round. Depending upon the type of reciprocating engine, the nose or front area of the crankcase varies somewhat. If the propeller is driven directly by the crankshaft, less area is needed for this component of the engine. The crankcases used on engines having opposed or inline cylinder arrangements vary in form for the different types of engines, but in general they are approximately cylindrical. One or more sides are surfaced to serve as a base to which the cylinders are attached by means of cap screws, bolts, or studs. These accurately machined surfaces are frequently referred to as cylinder pads.

If the propeller is driven by reduction gearing (gears that slow down the speed of the propeller less than the engine), more area is required to house the reduction gears. A tapered nose section is used quite frequently on direct-drive, low-powered engines, because extra space is not required to house the propeller reduction gears. Crankcase nose sections are usually cast of either aluminum alloy or magnesium. The crankcase nose section on engines that develop from 1,000 to 2,500 hp is usually larger to house reduction gears and sometimes ribbed to get as much strength as possible.

The governor is used to control propeller speed and blade angle. The mounting of the propeller governor varies. On some engines, it is located on the rear section, although this complicates the installation, especially if the propeller is operated or controlled by oil pressure, because of the distance between the governor and propeller. Where hydraulically operated propellers are used, it is good practice to mount the governor on the nose section as close to the propeller as possible to reduce the length of the oil passages. The governor is then driven either from gear teeth on the periphery of the bell gear or by some other suitable means. This basic

arrangement is also used for turboprops.

On some of the larger radial engines, a small chamber is located on the bottom of the nose section to collect the oil. This is called the nose section oil sump. Since the nose section transmits many varied forces to the main crankcase or power section, it must be secured properly to transmit the loads efficiently.

The machined surfaces on which the cylinders are mounted are called cylinder pads. They are provided with a suitable means of retaining or fastening the cylinders to the crankcase. The general practice in securing the cylinder flange to the pad is to mount studs in threaded holes in the crankcase. The inner portion of the cylinder pads are sometimes chamfered or tapered to permit the installation of a large rubber O-ring around the cylinder skirt, which effectively seals the joint between the cylinder and the crankcase pads against oil leakage.

Because oil is thrown about the crankcase, especially on inverted inline and radial-type engines, the cylinder skirts extend a considerable distance into the crankcase sections to reduce the flow of oil into the inverted cylinders. The piston and ring assemblies must be arranged so that they throw out the oil splashed directly into them.

Mounting lugs are spaced about the periphery of the rear of the crankcase or the diffuser section of a radial engine. These are used to attach the engine assembly to the engine mount or framework provided for attaching the powerplant to the fuselage of single-engine aircraft or to the wing nacelle structure of multiengine aircraft. The mounting lugs may be either integral with the crankcase or diffuser section or detachable, as in the case of flexible or dynamic engine mounts.

The mounting arrangement supports the entire powerplant including the propeller, and therefore is designed to provide ample strength for rapid maneuvers or other loadings. Because of the elongation and contraction of the cylinders, the intake pipes which carry the mixture from the diffuser chamber through the intake valve ports are arranged to provide a slip joint which must be leak proof. The atmospheric pressure on the outside of the case of an un-supercharged engine is higher than on the inside, especially when the engine is operating at idling speed. If the engine is equipped with a supercharger and operated at full throttle, the pressure is considerably higher on the inside than on the outside of the case. If the slip joint connection has a slight leakage, the engine may idle fast due to a slight leaning of the mixture. If the leak is quite large, it may not idle at all. At open throttle, a small leak probably would not be noticeable in operation of the engine, but the slight leaning of the air-fuel mixture might cause detonation or damage to the valves and valve seats. On some radial engines, the intake pipe has considerable length

and on some inline engines, the intake pipe is at right angles to the cylinders. In these cases, flexibility of the intake pipe or its arrangement eliminates the need for a slip joint. In any case, the engine induction system must be arranged so that it does not leak air and change the desired air-fuel ratio.

### Accessory Section

The accessory (rear) section usually is of cast construction and the material may be either aluminum alloy, which is used most widely, or magnesium, which has been used to some extent. On some engines, it is cast in one piece and provided with means for mounting the accessories, such as magnetos, carburetors, fuel, oil, vacuum pumps, starter, generator, tachometer drive, etc., in the various locations required to facilitate accessibility. Other adaptations consist of an aluminum alloy casting and a separate cast magnesium cover plate on which the accessory mounts are arranged. Accessory drive shafts are mounted in suitable drive arrangements that are carried out to the accessory mounting pads. In this manner, the various gear ratios can be arranged to give the proper drive speed to magnetos, pumps, and other accessories to obtain correct timing or functioning.

### Accessory Gear Trains

Gear trains, containing both spur- and bevel-type gears, are used in the different types of engines for driving engine components and accessories. Spur-type gears are generally used to drive the heavier loaded accessories or those requiring the least play or backlash in the gear train. Bevel gears permit angular location of short stub shafts leading to the various accessory mounting pads. On opposed, reciprocating engines, the accessory gear trains are usually simple arrangements. Many of these engines use simple gear trains to drive the engine's accessories at the proper speeds.

### Crankshafts

The crankshaft is carried in a position parallel to the longitudinal axis of the crankcase and is generally supported by a main bearing between each throw. The crankshaft main bearings must be supported rigidly in the crankcase. This usually is accomplished by means of transverse webs in the crankcase, one for each main bearing. The webs form an integral part of the structure and, in addition to supporting the main bearings, add to the strength of the entire case.

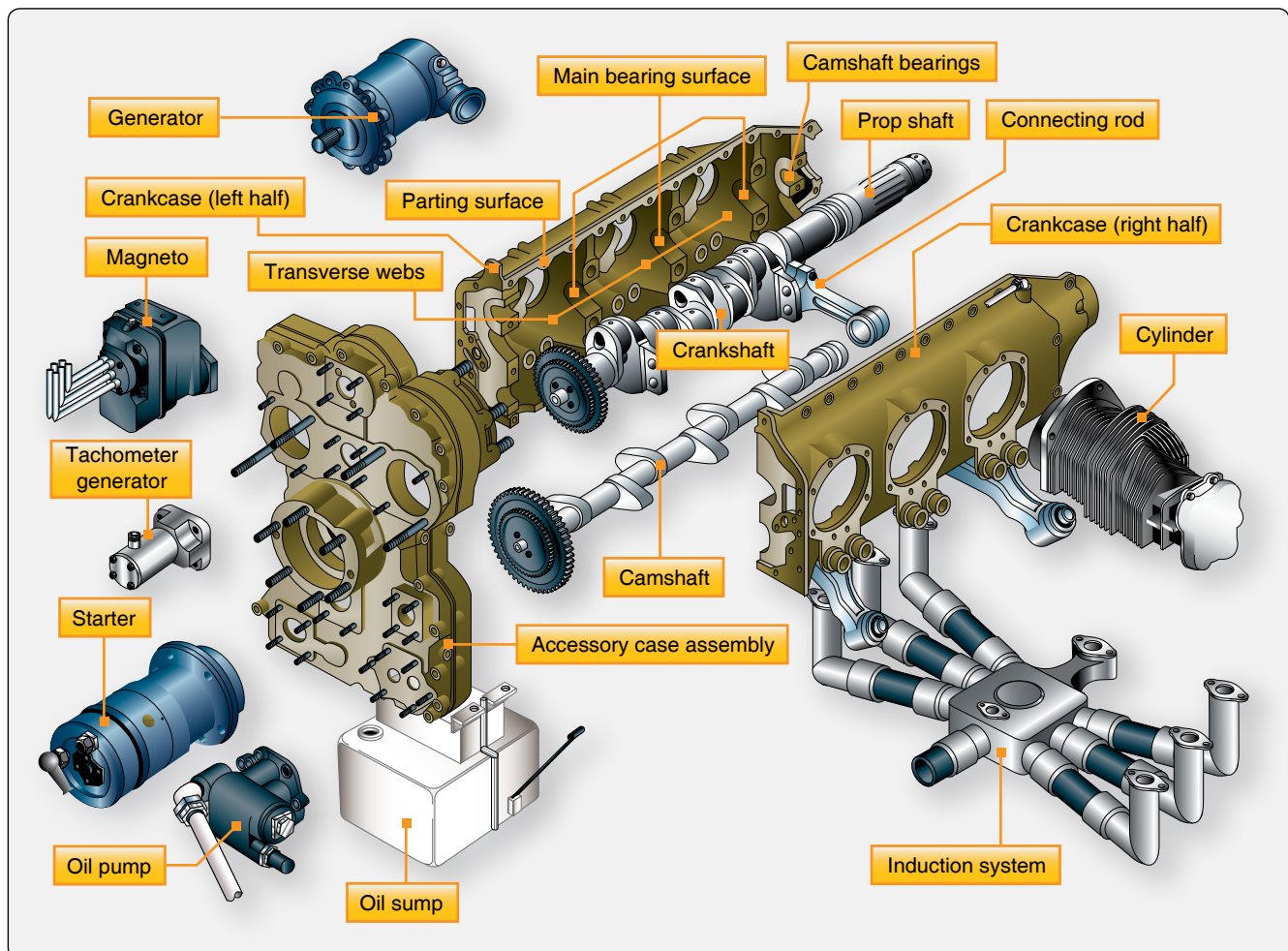

Figure 1-6. Typical opposed engine exploded into component assemblies.

The crankcase is divided into two sections in a longitudinal plane. This division may be in the plane of the crankshaft so that one-half of the main bearing (and sometimes camshaft bearings) are carried in one section of the case and the other half in the opposite section. [Figure 1-6] Another method is to divide the case in such a manner that the main bearings are secured to only one section of the case on which the cylinders are attached, thereby providing means of removing a section of the crankcase for inspection without disturbing the bearing adjustment.

The crankshaft is the backbone of the reciprocating engine. It is subjected to most of the forces developed by the engine. Its main purpose is to transform the reciprocating motion of the piston and connecting rod into rotary motion for rotation of the propeller. The crankshaft, as the name implies, is a shaft composed of one or more cranks located at specified points along its length. The cranks, or throws, are formed by forging offsets into a shaft before it is machined. Since crankshafts must be very strong, they generally are forged from a very strong alloy, such as chromium-nickel-molybdenum steel.

A crankshaft may be of single-piece or multipiece construction. Figure 1-7 shows two representative types of solid crankshafts used in aircraft engines. The four-throw construction may be used either on four-cylinder horizontal opposed or four-cylinder inline engines. The six-throw shaft is used on six-cylinder inline engines, 12-cylinder V-type engines, and six-cylinder opposed engines. Crankshafts of radial engines may be the single-throw, two-throw, or four-throw type, depending on whether the engine is the single-row, twin-row, or four-row type. A single-throw radial engine crankshaft is shown in Figure 1-8. No matter how many throws it may have, each crankshaft has three main parts—a journal, crankpin, and crank cheek. Flyweights and dampers, although not a true part of a crankshaft, are usually attached to it to reduce engine vibration.

The journal is supported by, and rotates in, a main bearing. It serves as the center of rotation of the crankshaft. It is surface-hardened to reduce wear. The crankpin is the section to which the connecting rod is attached. It is off-center from the main journals and is often called the throw. Two crank cheeks and a crankpin make a throw. When a force is applied to the crankpin in any direction other than parallel or perpendicular to and through the center line of the crankshaft, it causes the crankshaft to rotate. The outer surface is hardened by nitriding to increase its resistance to wear and to provide the required bearing surface. The crankpin is usually hollow. This reduces the total weight of the crankshaft and provides a passage for the transfer of lubricating oil. On early engines, the hollow crankpin also served as a chamber for collecting sludge, carbon deposits, and other foreign material. Centrifugal force

threw these substances to the outside of the chamber and kept them from reaching the connecting-rod bearing surface. Due to the use of ashless dispersant oils, newer engines no longer use sludge chambers. On some engines, a passage is drilled in the crank cheek to allow oil from the hollow crankshaft to be sprayed on the cylinder walls. The crank cheek connects the crankpin to the main journal. In some designs, the cheek extends beyond the journal and carries a flyweight to balance the crankshaft. The crank cheek must be of sturdy construction to obtain the required rigidity between the crankpin and the journal.

In all cases, the type of crankshaft and the number of crankpins must correspond with the cylinder arrangement of the engine. The position of the cranks on the crankshaft in relation to the other cranks of the same shaft is expressed in degrees.

The simplest crankshaft is the single-throw or 360° type. This type is used in a single-row radial engine. It can be constructed in one or two pieces. Two main bearings (one on each end) are provided when this type of crankshaft is used. The double-throw or 180° crankshaft is used on double-row radial engines. In the radial-type engine, one throw is provided for each row of cylinders.

### **Crankshaft Balance**

Excessive vibration in an engine not only results in fatigue failure of the metal structures, but also causes the moving parts to wear rapidly. In some instances, excessive vibration is caused by a crankshaft that is not balanced. Crankshafts are balanced for static balance and dynamic balance. A crankshaft is statically balanced when the weight of the entire assembly of crankpins, crank cheeks, and flyweights is balanced around the axis of rotation. When checked for static balance, it is placed on two knife edges. If the shaft tends to turn toward any one position during the test, it is out of static balance. Any engine to be overhauled completely should receive a runout check of its crankshaft as a first step. Any question concerning crankshaft replacement is resolved at this time since a shaft whose runout is beyond limits must be replaced.

### **Dynamic Dampers**

A crankshaft is dynamically balanced when all the forces created by crankshaft rotation and power impulses are balanced within themselves so that little or no vibration is produced when the engine is operating. To reduce vibration to a minimum during engine operation, dynamic dampers are incorporated on the crankshaft. A dynamic damper is merely a pendulum that is fastened to the crankshaft so that it is free to move in a small arc. It is incorporated in the flyweight assembly. Some crankshafts incorporate two or more of these assemblies, each being attached to a different crank cheek. The distance the pendulum moves and, thus, its vibrating

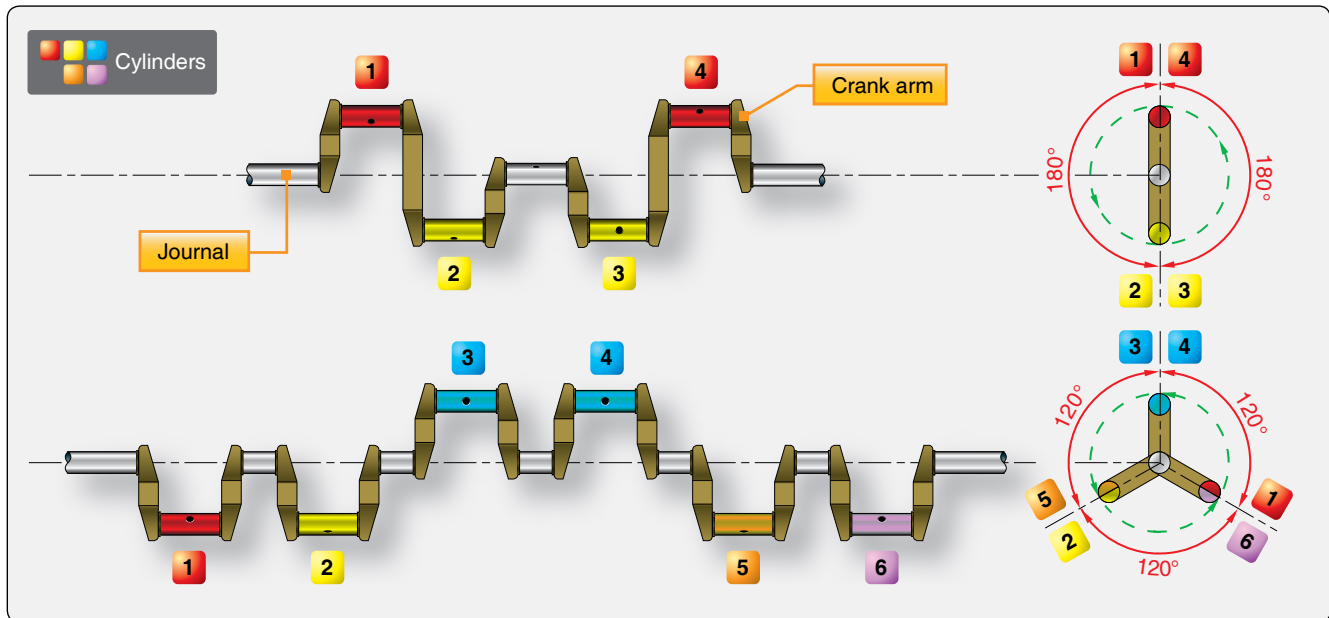

Figure 1-7. Solid types of crankshafts.

frequency corresponds to the frequency of the power impulses of the engine. When the vibration frequency of the crankshaft occurs, the pendulum oscillates out of time with the crankshaft vibration, thus reducing vibration to a minimum.

The construction of the dynamic damper used in one engine consists of a movable slotted-steel flyweight attached to the

crank cheek. Two spool-shaped steel pins extend into the slot and pass through oversized holes in the flyweight and crank cheek. The difference in the diameter between the pins and the holes provides a pendulum effect. An analogy of the functioning of a dynamic damper is shown in *Figure 1-9*.

### Connecting Rods

The connecting rod is the link that transmits forces between the piston and the crankshaft. [Figure 1-10] Connecting rods must be strong enough to remain rigid under load and yet be light enough to reduce the inertia forces that are produced when the rod and piston stop, change direction, and start again at the end of each stroke.

There are four types of connecting-rod assemblies [Figure 1-11]:

1. Plain.
2. Fork and blade.
3. Master and articulated.
4. Split-type.

### Master-and-Articulated Rod Assembly

The master-and-articulated rod assembly is commonly used in radial engines. In a radial engine, the piston in one cylinder in each row is connected to the crankshaft by a master rod. All other pistons in the row are connected to the master rod by articulated rods. In an 18-cylinder engine, which has two rows of cylinders, there are two master rods and 16 articulated rods. The articulated rods are constructed of forged steel alloy in either the I- or H-shape, denoting the cross-sectional shape. Bronze bushings are pressed into the

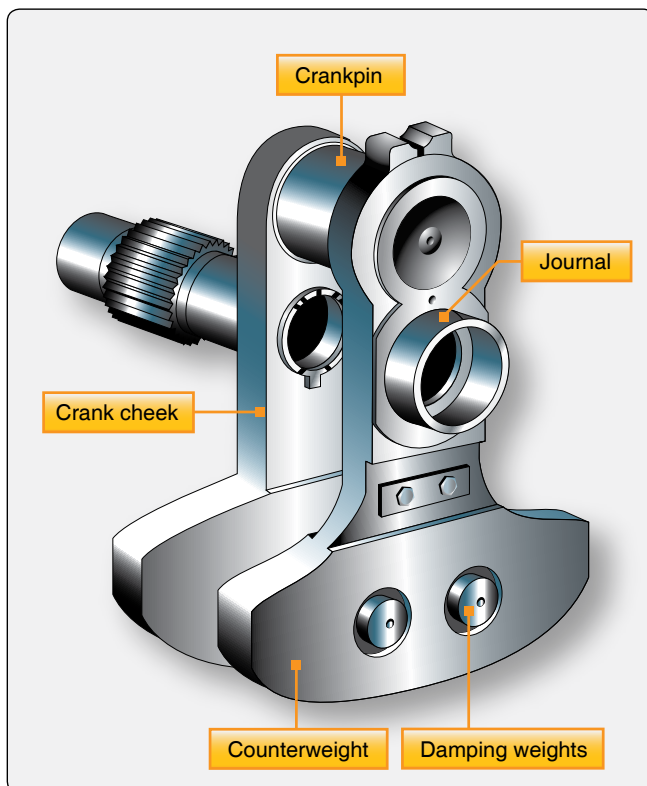
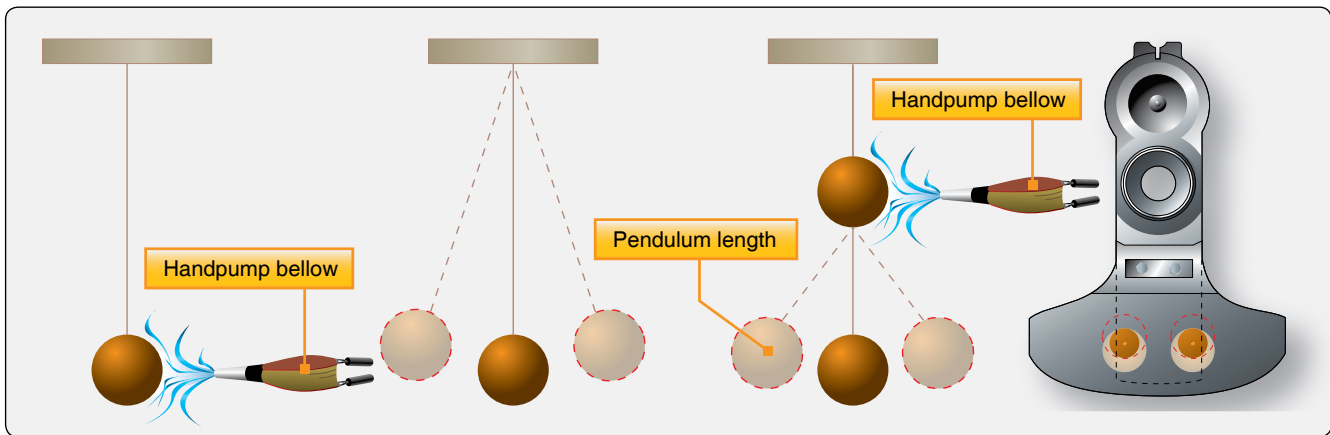

Figure 1-8. A single-throw radial engine crankshaft.



**Figure 1-9.** Principles of a dynamic damper.

bores in each end of the articulated rod to provide knuckle-pin and piston-pin bearings.

The master rod serves as the connecting link between the piston pin and the crankpin. The crankpin end, or the big end, contains the crankpin or master rod bearing. Flanges around the big end provide for the attachment of the articulated rods. The articulated rods are attached to the master rod by knuckle pins, which are pressed into holes in the master rod flanges during assembly. A plain bearing, usually called a piston-pin bushing, is installed in the piston end of the master rod to receive the piston pin.

When a crankshaft of the split-spline or split-clamp type is employed, a one-piece master rod is used. The master and articulated rods are assembled and then installed on the crankpin; the crankshaft sections are then joined together. In engines that use the one-piece type of crankshaft, the big end of the master rod is split, as is the master rod bearing. The main part of the master rod is installed on the crankpin; then the bearing cap is set in place and bolted to the master rod. The centers of the knuckle pins do not coincide with the center of the crankpin. Thus, while the crankpin center describes a true circle for each revolution of the crankshaft, the centers of the knuckle pins describe an elliptical path. [Figure 1-12] The elliptical paths are symmetrical about a center line through the master rod cylinder. It can be seen that the major diameters of the ellipses are not the same. Thus, the link rods have varying degrees of angularity relative to the center of the crank throw.

Because of the varying angularity of the link rods and the elliptical motion of the knuckle pins, all pistons do not move an equal amount in each cylinder for a given number of degrees of crank throw movement. This variation in piston position between cylinders can have considerable effect on engine operation. To minimize the effect of these factors on valve and ignition timing, the knuckle pin holes in the master rod flange are not equidistant from the center of the crankpin, thereby

offsetting to an extent the effect of the link rod angularity.

Another method of minimizing the adverse effects on engine operation is to use a compensated magneto. In this magneto the breaker cam has a number of lobes equal to the number of cylinders on the engine. To compensate for the variation in piston position due to link rod angularity, the breaker cam lobes are ground with uneven spacing. This allows the breaker contacts to open when the piston is in the correct firing position. This is further outlined during the discussion on ignition timing in Chapter 4, Engine Ignition & Electrical Systems.

### Knuckle Pins

The knuckle pins are of solid construction except for the oil passages drilled in the pins, which lubricate the knuckle pin bushings. These pins may be installed by pressing into holes in the master rod flanges so that they are prevented from turning in the master rod. Knuckle pins may also be installed with a loose fit so that they can turn in the master rod flange holes, and also turn in the articulating rod bushings. These are called full-floating knuckle pins. In either type of installation, a lock plate on each side retains the knuckle pin and prevents a lateral movement.



**Figure 1-10.** A connecting rod between the piston and crankshaft.

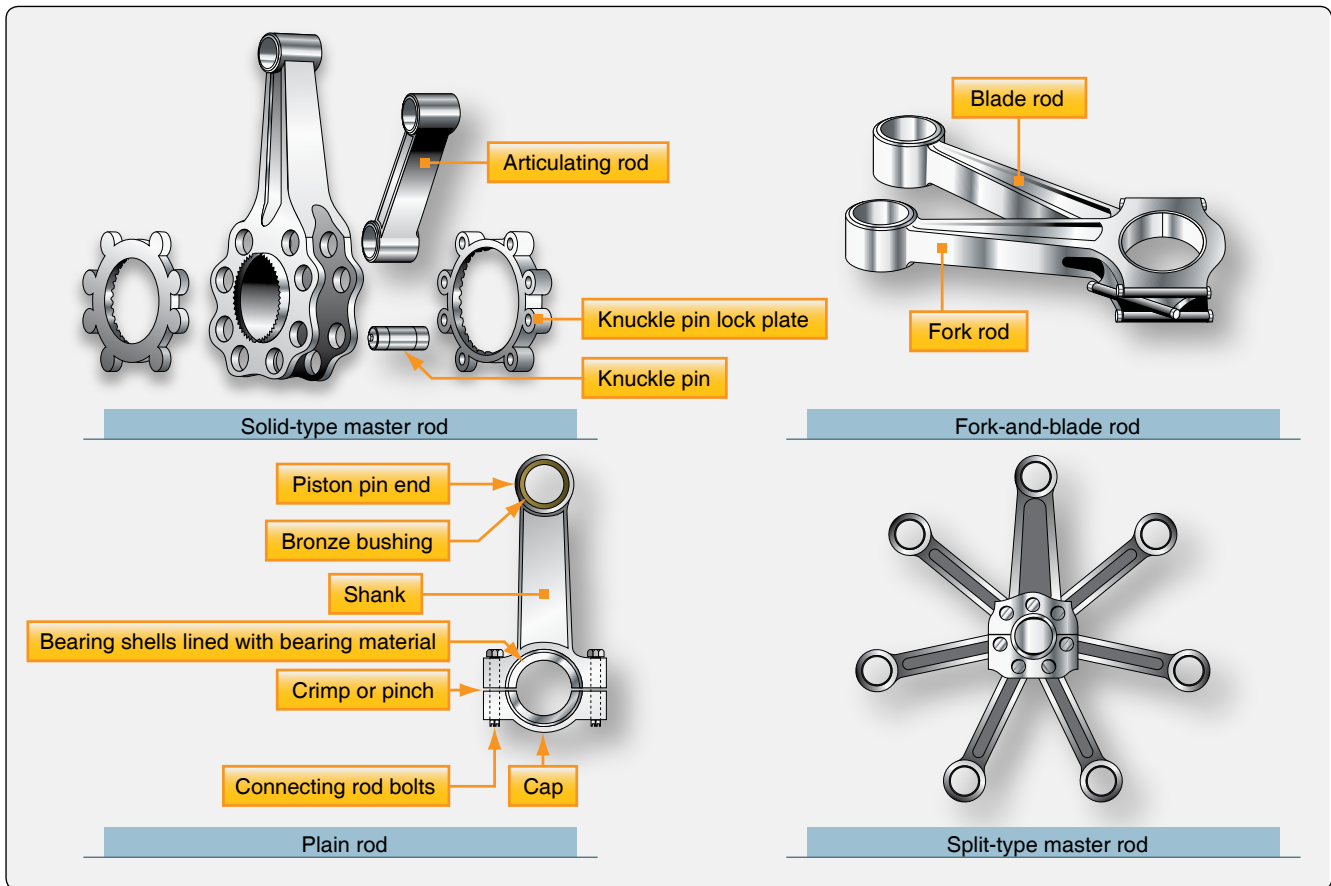

Figure 1-11. Connecting rod assemblies.

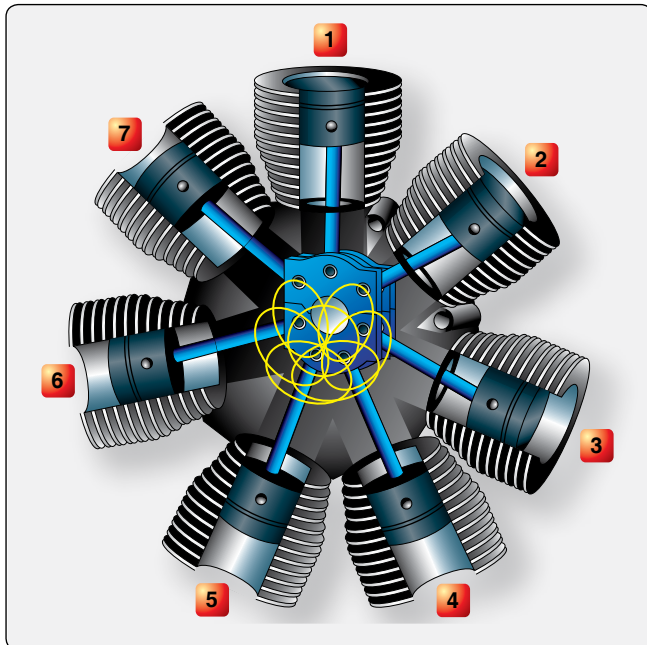

Figure 1-12. Elliptical travel path of knuckle pins in an articulated rod assembly.

### Plain-Type Connecting Rods

Plain-type connecting rods are used in inline and opposed engines. The end of the rod attached to the crankpin is fitted with a cap and a two-piece bearing. The bearing cap is held on the end of the rod by bolts or studs. To maintain proper fit and balance, connecting rods should always be replaced in the same cylinder and in the same relative position.

### Fork-and-Blade Rod Assembly

The fork-and-blade rod assembly is used primarily in V-type engines. The forked rod is split at the crankpin end to allow space for the blade rod to fit between the prongs. A single two-piece bearing is used on the crankshaft end of the rod. This type of connecting rod is not used much on modern engines.

### Pistons

The piston of a reciprocating engine is a cylindrical member which moves back and forth within a steel cylinder. [Figure 1-13] The piston acts as a moving wall within the combustion chamber. As the piston moves down in the cylinder, it draws in the air-fuel mixture. As it moves upward, it compresses the charge, ignition occurs, and the expanding gases force the piston downward. This force is transmitted to the crankshaft through the connecting rod. On the return upward stroke, the piston forces the exhaust gases from the cylinder and the cycle repeats.



Figure 1-13. A piston.

strength or wear resistance. The top of the piston, or head, may be flat, convex, or concave. Recesses may be machined in the piston head to prevent interference with the valves.

Modern engines use cam ground pistons that are a larger diameter perpendicular to the piston pin. This larger diameter keeps the piston straight in the cylinder as the engine warms up from initial startup. As the piston heats up during warm up, the part of the piston in line with the pin has more mass and expands more making the piston completely round. At low temperatures, the piston is oval shaped and, when it warms to operating temperature, it becomes round. This process reduces the tendency of the piston to cock or slap in the cylinder during warm up. When the engine reaches its normal operating temperature, the piston assumes the correct dimensions in the cylinder.

### Piston Construction

The majority of aircraft engine pistons are machined from aluminum alloy forgings. Grooves are machined in the outside surface of the piston to receive the piston rings, and cooling fins are provided on the inside of the piston for greater heat transfer to the engine oil.

Pistons may be either the trunk type or the slipper type. [Figure 1-14] Slipper-type pistons are not used in modern, high-powered engines because they do not provide adequate

As many as six grooves may be machined around the piston to accommodate the compression rings and oil rings. [Figure 1-15] The compression rings are installed in the three uppermost grooves; the oil control rings are installed immediately above the piston pin. The piston is usually drilled at the oil control ring grooves to allow surplus oil scraped from the cylinder walls by the oil control rings to pass back into the crankcase. An oil scraper ring is installed at the base of the piston wall or skirt to prevent excessive oil consumption. The portions of the piston walls that lie between

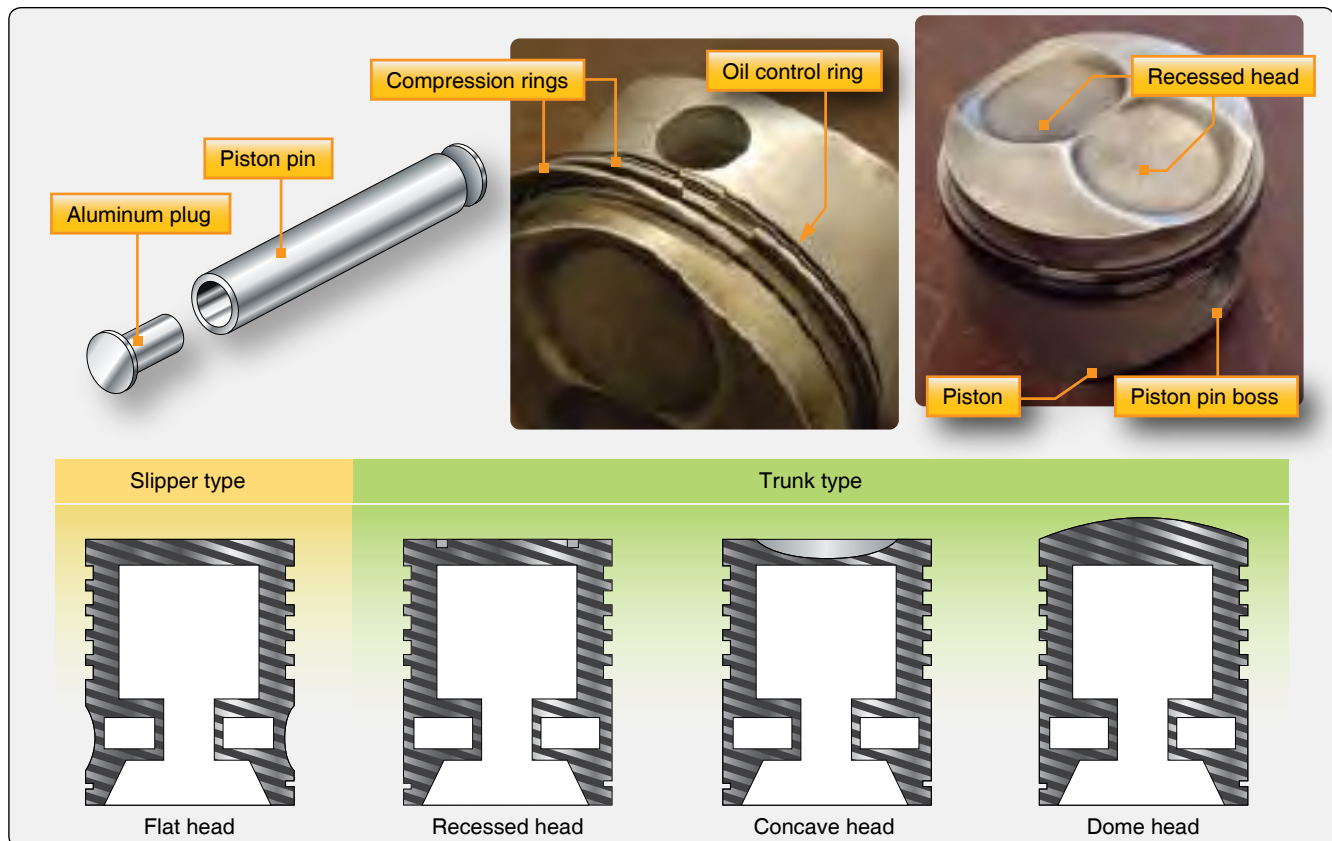

Figure 1-14. Piston assembly and types of pistons.

ring grooves are called the ring lands. In addition to acting as a guide for the piston head, the piston skirt incorporates the piston-pin bosses. The piston-pin bosses are of heavy construction to enable the heavy load on the piston head to be transferred to the piston pin.

### Piston Pin

The piston pin joins the piston to the connecting rod. It is machined in the form of a tube from a nickel steel alloy forging, casehardened, and ground. The piston pin is sometimes called a wristpin because of the similarity between the relative motions of the piston and the articulated rod and that of the human arm. The piston pin used in modern aircraft engines is the full-floating type, so called because the pin is free to rotate in both the piston and in the connecting rod piston-pin bearing. The piston pin must be held in place to prevent the pin ends from scoring the cylinder walls. A plug of relatively soft aluminum in the pin end provides a good bearing surface against the cylinder wall.

### Piston Rings

The piston rings prevent leakage of gas pressure from the combustion chamber and reduce to a minimum the seepage of oil into the combustion chamber. [Figure 1-15] The rings fit into the piston grooves but spring out to press against the cylinder walls; when properly lubricated, the rings form an effective gas seal.

### Piston Ring Construction

Most piston rings are made of high-grade cast iron. [Figure 1-14] After the rings are made, they are ground to



Figure 1-15. Machined rings around a piston.

the cross-section desired. Then they are split so that they can be slipped over the outside of the piston and into the ring grooves that are machined in the piston wall. Since their purpose is to seal the clearance between the piston and the cylinder wall, they must fit the cylinder wall snugly enough to provide a gastight fit. They must exert equal pressure at all points on the cylinder wall and must make a gastight fit against the sides of the ring grooves.

Gray cast iron is most often used in making piston rings. In some engines, chrome-plated mild steel piston rings are used in the top compression ring groove because these rings can better withstand the high temperatures present at this point. Chrome rings must be used with steel cylinder walls. Never use chrome rings on chrome cylinders.

### Compression Ring

The purpose of the compression rings is to prevent the escape of combustion gases past the piston during engine operation. They are placed in the ring grooves immediately below the piston head. The number of compression rings used on each piston is determined by the type of engine and its design, although most aircraft engines use two compression rings plus one or more oil control rings.

The cross-section of the ring is either rectangular or wedge shaped with a tapered face. The tapered face presents a narrow bearing edge to the cylinder wall, which helps to reduce friction and provide better sealing.

### Oil Control Rings

Oil control rings are placed in the grooves immediately below the compression rings and above the piston pin bores. There may be one or more oil control rings per piston; two rings may be installed in the same groove, or they may be installed in separate grooves. Oil control rings regulate the thickness of the oil film on the cylinder wall. If too much oil enters the combustion chamber, it burns and leaves a thick coating of carbon on the combustion chamber walls, the piston head, the spark plugs, and the valve heads. This carbon can cause the valves and piston rings to stick if it enters the ring grooves or valve guides. In addition, the carbon can cause spark plug misfiring as well as detonation, pre-ignition, or excessive oil consumption. To allow the surplus oil to return to the crankcase, holes are drilled in the bottom of the oil control piston ring grooves or in the lands next to these grooves.

### Oil Scrapper Ring

The oil scrapper ring usually has a beveled face and is installed in the groove at the bottom of the piston skirt. The ring is installed with the scraping edge away from the piston head or in the reverse position, depending upon cylinder position and the engine series. In the reverse position, the scrapper ring

retains the surplus oil above the ring on the upward piston stroke, and this oil is returned to the crankcase by the oil control rings on the downward stroke.

## Cylinders

The portion of the engine in which the power is developed is called the cylinder. [Figure 1-16] The cylinder provides a combustion chamber where the burning and expansion of gases take place, and it houses the piston and the connecting rod. There are four major factors that need to be considered in the design and construction of the cylinder assembly. It must:

1. Be strong enough to withstand the internal pressures developed during engine operation.
2. Be constructed of a lightweight metal to keep down engine weight.
3. Have good heat-conducting properties for efficient cooling.
4. Be comparatively easy and inexpensive to manufacture, inspect, and maintain.

The cylinder head of an air cooled engine is generally made of aluminum alloy because aluminum alloy is a good conductor of heat and its light weight reduces the overall engine weight. Cylinder heads are forged or die-cast for greater strength. The inner shape of a cylinder head is generally semispherical. The semispherical shape is stronger than conventionalist



Figure 1-16. An example of an engine cylinder.

design and aids in a more rapid and thorough scavenging of the exhaust gases.

The cylinder used in the air cooled engine is the overhead valve type. [Figure 1-17] Each cylinder is an assembly of two major parts: cylinder head and cylinder barrel. At assembly, the cylinder head is expanded by heating and then screwed down on the cylinder barrel, which has been chilled. When the head cools and contracts and the barrel warms up and expands, a gastight joint results. The majority of the cylinders used are constructed in this manner using an aluminum head and a steel barrel. [Figure 1-18]

## Cylinder Heads

The purpose of the cylinder head is to provide a place for combustion of the air-fuel mixture and to give the cylinder more heat conductivity for adequate cooling. The air-fuel mixture is ignited by the spark in the combustion chamber and commences burning as the piston travels toward top dead center (top of its travel) on the compression stroke. The ignited charge is rapidly expanding at this time, and pressure is increasing so that, as the piston travels through the top dead center position, it is driven downward on the power stroke.

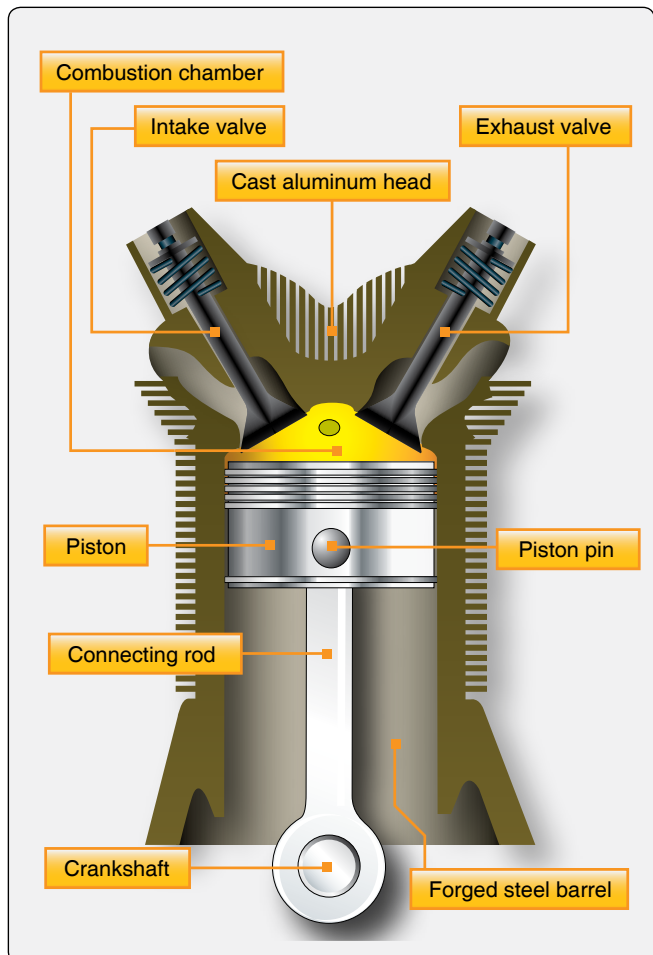

Figure 1-17. Cutaway view of the cylinder assembly.

The intake and exhaust valve ports are located in the cylinder head along with the spark plugs and the intake and exhaust valve actuating mechanisms.

After the cylinder head is cast, the spark plug bushings, valve guides, rocker arm bushings, and valve seats are installed in the cylinder head. Spark plug openings may be fitted with bronze or steel bushings that are shrunk and screwed into the openings. Stainless steel Heli-Coil spark plug inserts are used in many engines currently manufactured. Bronze or steel valve guides are usually shrunk or screwed into drilled openings in the cylinder head to provide guides for the valve stems. These are generally located at an angle to the center line of the cylinder. The valve seats are circular rings of hardened metal that protect the relatively soft metal of the cylinder head from the hammering action of the valves (as they open and close) and from the exhaust gases.

The cylinder heads of air cooled engines are subjected to extreme temperatures; it is therefore necessary to provide adequate cooling fin area and to use metals that conduct heat rapidly. Cylinder heads of air cooled engines are usually cast or forged. Aluminum alloy is used in the construction for a number of reasons. It is well adapted for casting or for the machining of deep, closely spaced fins, and it is more resistant than most metals to the corrosive attack of tetraethyl lead in gasoline. The greatest improvement in air cooling has resulted from reducing the thickness of the fins and increasing their depth. In this way, the fin area has been increased in modern engines. Cooling fins taper from 0.090" at the base to 0.060" at the tip end. Because of the difference in temperature in the various sections of the cylinder head, it is necessary to provide more cooling-fin area on some sections than on others. The exhaust valve region is the hottest part of the internal surface; therefore, more fin area is provided around the outside of the cylinder in this section.



Figure 1-18. The aluminum head and steel barrel of a cylinder.

## Cylinder Barrels

The cylinder barrel in which the piston operates must be made of a high-strength material, usually steel. It must be as light as possible yet have the proper characteristics for operating under high temperatures. It must be made of a good bearing material and have high tensile strength. The cylinder barrel is made of a steel alloy forging with the inner surface hardened to resist wear of the piston and the piston rings which bear against it. This hardening is usually done by exposing the steel to ammonia or cyanide gas while the steel is very hot. The steel soaks up nitrogen from the gas, which forms iron nitrides on the exposed surface. As a result of this process, the metal is said to be nitrided. This nitriding only penetrates into the barrel surface a few thousandths of an inch. As the cylinder barrels wear due to use, they can be repaired by chroming. This is a process that plates chromium on the surface of the cylinder barrel and brings it back to new standard dimensions. Chromium-plated cylinders should use cast iron rings. Honing the cylinder walls is a process that brings it to the correct dimensions and provides crosshatch pattern for seating the piston rings during engine break-in. Some engine cylinder barrels are choked at the top, or they are smaller in diameter to allow for heat expansion and wear.

In some instances, the barrel has threads on the outside surface at one end so that it can be screwed into the cylinder head. The cooling fins are machined as an integral part of the barrel and have limits on repair and service.

## Cylinder Numbering

Occasionally, it is necessary to refer to the left or right side of the engine or to a particular cylinder. Therefore, it is necessary to know the engine directions and how cylinders of an engine are numbered. The propeller shaft end of the engine is always the front end, and the accessory end is the rear end, regardless of how the engine is mounted in an aircraft. When referring to the right side or left side of an engine, always assume the view is from the rear or accessory end. As seen from this position, crankshaft rotation is referred to as either clockwise or counterclockwise.

Inline and V-type engine cylinders are usually numbered from the rear. In V-engines, the cylinder banks are known as the right bank and the left bank, as viewed from the accessory end. [Figure 1-19] The cylinder numbering of the opposed engine shown begins with the right rear as No. 1 and the left rear as No. 2. The one forward of No. 1 is No. 3; the one forward of No. 2 is No. 4, and so on. The numbering of opposed engine cylinders is by no means standard. Some manufacturers number their cylinders from the rear and others from the front of the engine. Always refer to the appropriate engine manual to determine the numbering system used by that manufacturer.

Single-row radial engine cylinders are numbered clockwise when viewed from the rear. Cylinder No. 1 is the top cylinder. In double-row engines, the same system is used. The No. 1 cylinder is the top one in the rear row. No. 2 cylinder is the first one clockwise from No. 1, but No. 2 is in the front row. No. 3 cylinder is the next one clockwise to No. 2 but is in the rear row. Thus, all odd-numbered cylinders are in the rear row, and all even-numbered cylinders are in the front row.

### Firing Order

The firing order of an engine is the sequence in which the power event occurs in the different cylinders. The firing order is designed to provide for balance and to eliminate vibration to the greatest extent possible. In radial engines, the firing order must follow a special pattern since the firing impulses must follow the motion of the crank throw during its rotation. In inline engines, the firing orders may vary somewhat, yet most orders are arranged so that the firing of cylinders is evenly distributed along the crankshaft. Six-cylinder inline engines generally have a firing order of 1-5-3-6-2-4. Cylinder firing order in opposed engines can usually be listed in pairs of cylinders, as each pair fires across the center main bearing. The firing order of six-cylinder opposed engines is 1-4-5-2-3-6. The firing order of one model four-cylinder opposed engine is 1-4-2-3, but on another model, it is 1-3-2-4.

### Single-Row Radial Engines

On a single-row radial engine, all the odd-numbered cylinders fire in numerical succession; then, the even numbered cylinders fire in numerical succession. On a five-cylinder radial engine, for example, the firing order is 1-3-5-2-4, and on a seven-cylinder radial engine it is 1-3-5-7-2-4-6. The firing order of a nine-cylinder radial engine is 1-3-5-7-9-2-4-6-8.

### Double-Row Radial Engines

On a double-row radial engine, the firing order is somewhat complicated. The firing order is arranged with the firing impulse occurring in a cylinder in one row and then in a cylinder in the other row; therefore, two cylinders in the same row never fire in succession.

An easy method for computing the firing order of a 14-cylinder, double-row radial engine is to start with any number from 1 to 14 and add 9 or subtract 5 (these are called the firing order numbers), whichever gives an answer between 1 and 14, inclusive. For example, starting with 8, 9 cannot be added since the answer would then be more than 14; therefore, subtract 5 from 8 to get 3, add 9 to 3 to get 12, subtract 5 from 12 to get 7, subtract 5 from 7 to get 2, and so on.

The firing order numbers of an 18-cylinder, double-row radial engine are 11 and 7; that is, begin with any number from 1 to 18 and add 11 or subtract 7. For example, beginning with 1, add 11 to get 12; 11 cannot be added to 12 because the total would be more than 18, so subtract 7 to get 5, add 11 to 5 to get 16, subtract 7 from 16 to get 9, subtract 7 from 9 to get 2, add 11 to 2 to get 13, and continue this process for 18 cylinders.

### Valves

The air-fuel mixture enters the cylinders through the intake valve ports, and burned gases are expelled through the exhaust valve ports. The head of each valve opens and closes these cylinder ports. The valves used in aircraft engines are the conventional poppet type. The valves are also typed by their shape and are called either mushroom or tulip because of their resemblance to the shape of these plants. *Figure 1-20* illustrates various shapes and types of these valves.

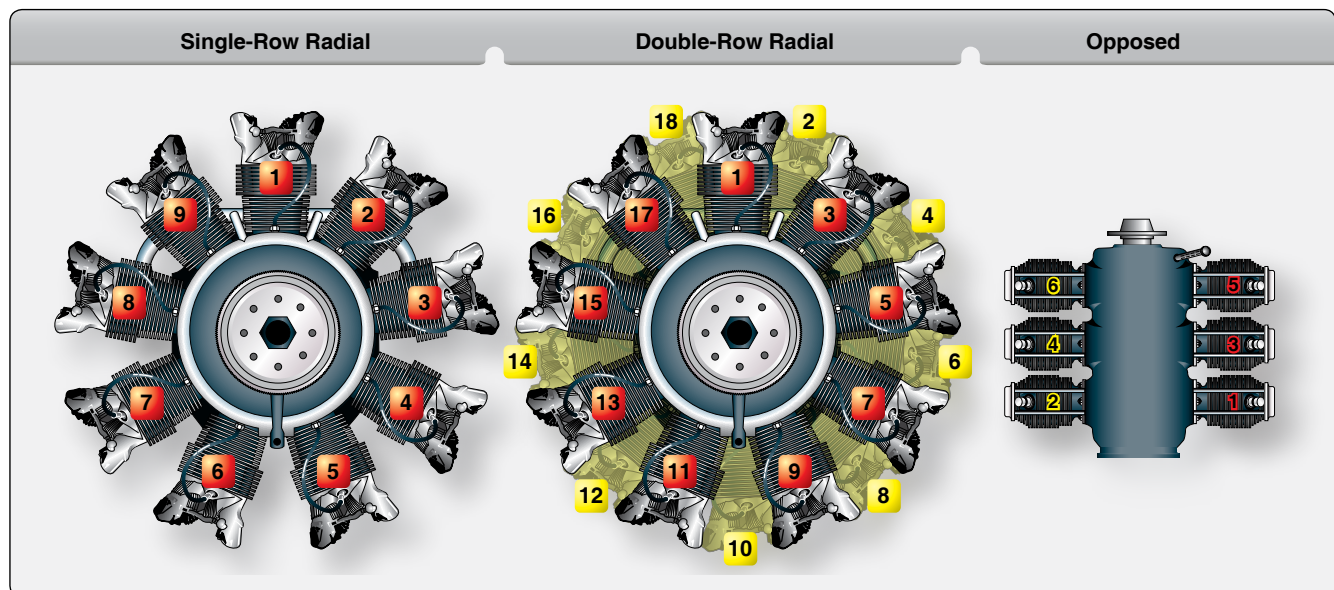

Figure 1-19. Numbering of engine cylinders.

**Valve Construction**

The valves in the cylinders of an aircraft engine are subjected to high temperatures, corrosion, and operating stresses; thus, the metal alloy in the valves must be able to resist all these factors. Because intake valves operate at lower temperatures than exhaust valves, they can be made of chromic-nickel steel. Exhaust valves are usually made of nichrome, silchrome, or cobalt-chromium steel because these materials are much more heat resistant.

The valve head has a ground face that forms a seal against the ground valve seat in the cylinder head when the valve is closed. The face of the valve is usually ground to an angle of either 30° or 45°. In some engines, the intake-valve face is ground to an angle of 30°, and the exhaust-valve face is ground to a 45° angle. Valve faces are often made more durable by the application of a material called stellite. About 1/16 inch of this alloy is welded to the valve face and ground to the correct angle. Stellite is resistant to high-temperature corrosion and also withstands the shock and wear associated with valve operation. Some engine manufacturers use a nichrome facing on the valves. This serves the same purpose as the stellite material.

The valve stem acts as a pilot for the valve head and rides in

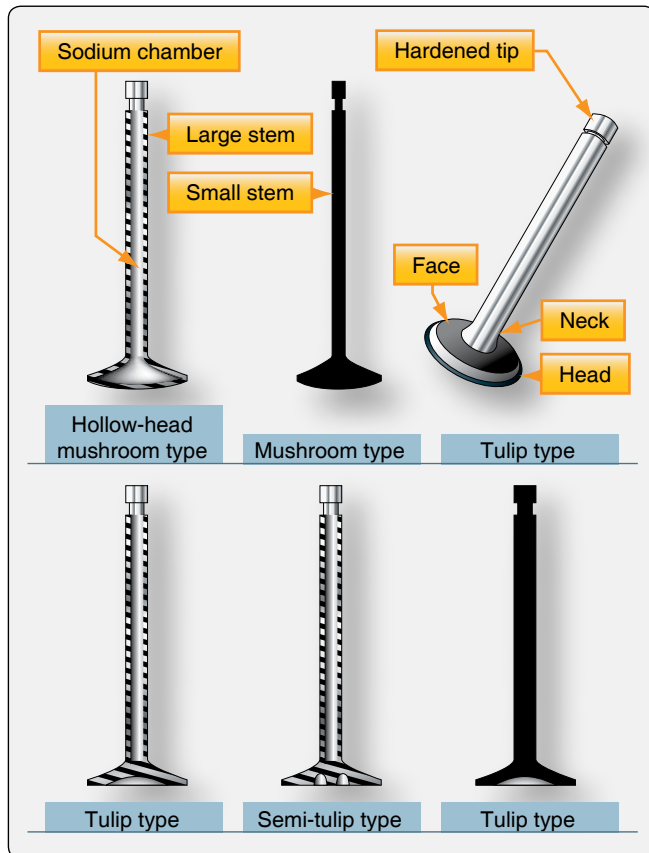

Figure 1-20. Various valve types.

the valve guide installed in the cylinder head for this purpose. [Figure 1-21] The valve stem is surface hardened to resist wear. The neck is the part that forms the junction between the head and the stem. The tip of the valve is hardened to withstand the hammering of the valve rocker arm as it opens the valve. A machined groove on the stem near the tip receives the split-ring stem keys. These stem keys form a lock ring to hold the valve spring retaining washer in place. [Figure 1-22]

Some intake and exhaust valve stems are hollow and partially filled with metallic sodium. This material is used because it is an excellent heat conductor. The sodium melts at approximately 208 °F and the reciprocating motion of the valve circulates the liquid sodium, allowing it to carry away heat from the valve head to the valve stem where it is dissipated through the valve guide to the cylinder head and the cooling fins. Thus, the operating temperature of the valve may be reduced as much as 300° to 400 °F. Under no circumstances should a sodium-filled valve be cut open



Figure 1-21. View of valve guide installed on a cylinder head.



Figure 1-22. Stem keys forming a lock ring to hold valve spring retaining washers in place.

or subjected to treatment which may cause it to rupture. Exposure of the sodium in these valves to the outside air results in fire or explosion with possible personal injury.

The most commonly used intake valves have solid stems, and the head is either flat or tulip shaped. Intake valves for low-power engines are usually flat headed. In some engines, the intake valve may be the tulip type and have a smaller stem than the exhaust valve or it may be similar to the exhaust valve but have a solid stem and head. Although these valves are similar, they are not interchangeable since the faces of the valves are constructed of different material. The intake valve usually has a flat milled on the tip to identify it.

### Valve Operating Mechanism

For a reciprocating engine to operate properly, each valve must open at the proper time, stay open for the required length of time, and close at the proper time. Intake valves are opened just before the piston reaches top dead center, and exhaust valves remain open after top dead center. At a particular instant, therefore, both valves are open at the same time (end of the exhaust stroke and beginning of the intake stroke). This valve overlap permits better volumetric efficiency and lowers the cylinder operating temperature. This timing of the valves is controlled by the valve-operating mechanism and is referred to as the valve timing.

The valve lift (distance that the valve is lifted off its seat) and the valve duration (length of time the valve is held open) are both determined by the shape of the cam lobes. Typical cam lobes are illustrated in *Figure 1-23*. The portion of the lobe that gently starts the valve operating mechanism moving is called a ramp, or step. The ramp is machined on each side of

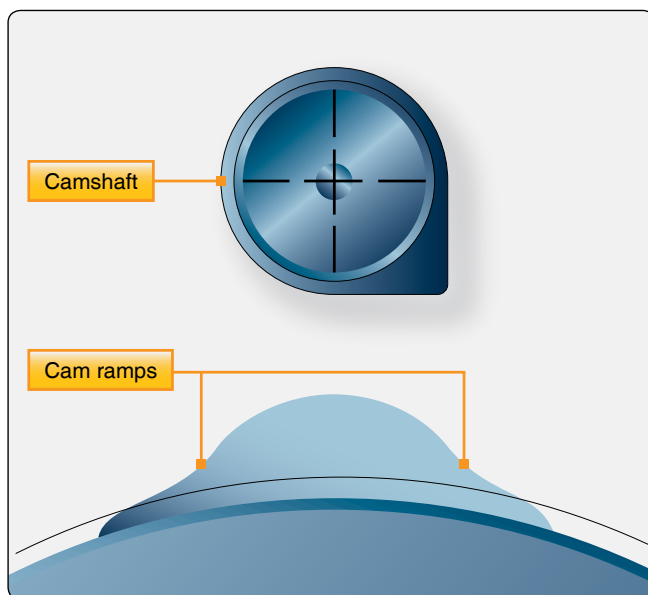

Figure 1-23. Typical cam lobes.

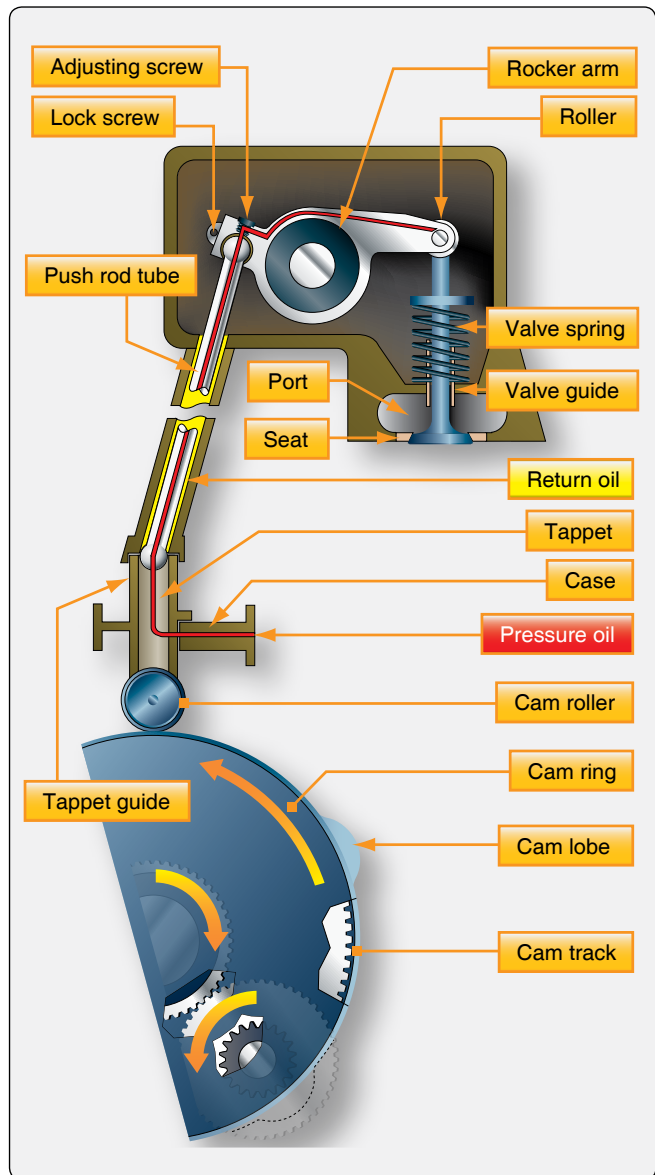
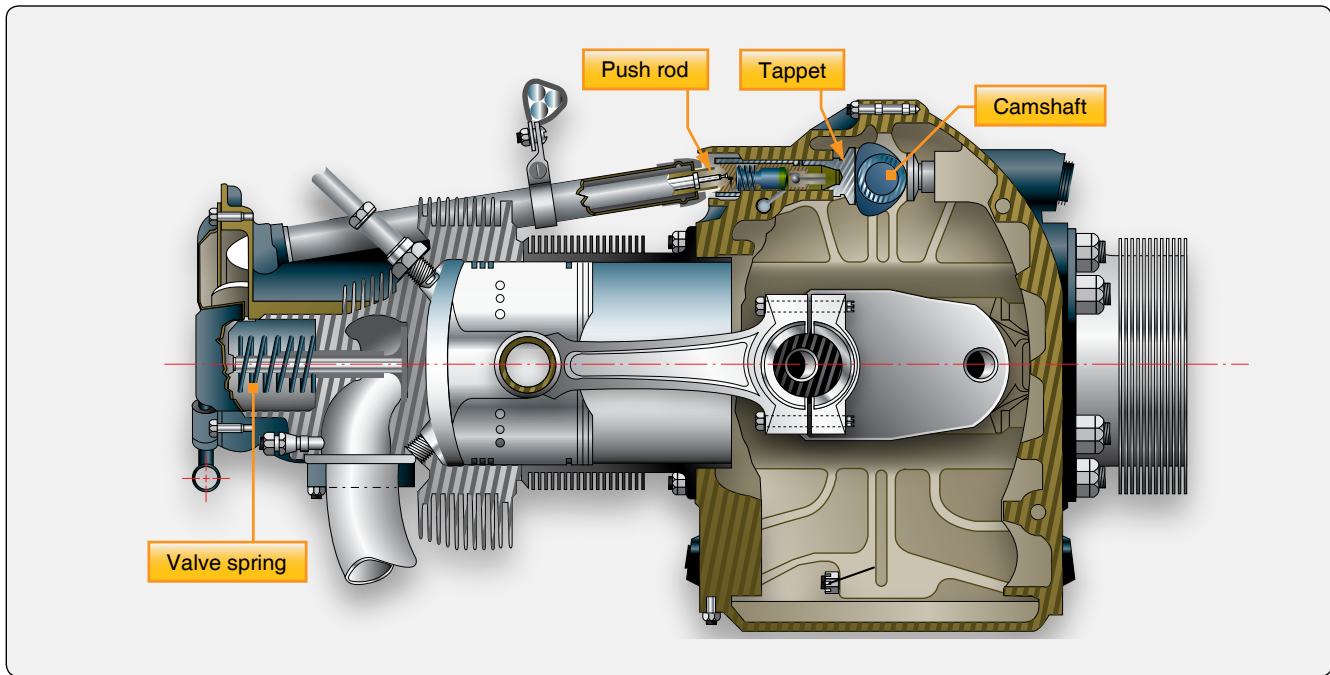

Figure 1-24. Valve-operating mechanism (radial engine).

the cam lobe to permit the rocker arm to be eased into contact with the valve tip and thus reduce the shock load which would otherwise occur. The valve operating mechanism consists of a cam ring or camshaft equipped with lobes that work against a cam roller or a cam follower. [Figures 1-24 and 1-25] The cam follower pushes a push rod and ball socket, actuating a rocker arm, which in turn opens the valve. Springs, which slip over the stem of the valves and are held in place by the valve-spring retaining washer and stem key, close each valve and push the valve mechanism in the opposite direction. [Figure 1-26]

### Cam Rings

The valve mechanism of a radial engine is operated by one or two cam rings, depending upon the number of rows of cylinders. In a single-row radial engine, one ring with a double cam track is used. One track operates the intake valves, the other



**Figure 1-25.** Valve-operating mechanism (opposed engine).

operates the exhaust valves. The cam ring is a circular piece of steel with a series of cams or lobes on the outer surface. The surface of these lobes and the space between them (on which the cam rollers ride) is known as the cam track. As the cam ring revolves, the lobes cause the cam roller to raise the tappet in the tappet guide, thereby transmitting the force through the push rod and rocker arm to open the valve. In a single-row radial engine, the cam ring is usually located between the propeller reduction gearing and the front end of the power section. In a twin-row radial engine, a second cam for the operation of the valves in the rear row is installed between the rear end of the power section and the supercharger section.

The cam ring is mounted concentrically with the crankshaft and is driven by the crankshaft at a reduced rate of speed

through the cam intermediate drive gear assembly. The cam ring has two parallel sets of lobes spaced around the outer periphery, one set (cam track) for the intake valves and the other for the exhaust valves. The cam rings used may have four or five lobes on both the intake and the exhaust tracks. The timing of the valve events is determined by the spacing of these lobes and the speed and direction at which the cam rings are driven in relation to the speed and direction of the crankshaft. The method of driving the cam varies on different makes of engines. The cam ring can be designed with teeth on either the inside or outside periphery. If the reduction gear meshes with the teeth on the outside of the ring, the cam turns in the direction of rotation of the crankshaft. If the ring is driven from the inside, the cam turns in the opposite direction from the crankshaft. [Figure 1-24]



**Figure 1-26.** A typical set of valve springs used to dampen oscillations. Multiple springs are used to protect against breakage.

A four-lobe cam may be used on either a seven-cylinder or nine-cylinder engine. [Figure 1-27] On the seven cylinder, it rotates in the same direction as the crankshaft, and on the nine cylinder, opposite the crankshaft rotation. On the nine-cylinder engine, the spacing between cylinders is  $40^\circ$  and the firing order is 1-3-5-7-9-2-4-6-8. This means that there is a space of  $80^\circ$  between firing impulses. The spacing on the four lobes of the cam ring is  $90^\circ$ , which is greater than the spacing between impulses. Therefore, to obtain proper relation of valve operations and firing order, it is necessary to drive the cam opposite the crankshaft rotation. Using the four-lobe cam on the seven-cylinder engine, the spacing between the firing of the cylinders is greater than the spacing of the cam lobes. Therefore, it is necessary for the cam to rotate in the same direction as the crankshaft.

5 Cylinders		7 Cylinders		9 Cylinders		Direction of Rotation
Number of Lobes	Speed	Number of Lobes	Speed	Number of Lobes	Speed	
3	1/6	4	1/8	5	1/10	with crankshaft
2	1/4	3	1/6	4	1/8	opposite crankshaft

Figure 1-27. Radial engines, cam ring table.

**Camshaft**

The valve mechanism of an opposed engine is operated by a camshaft. The camshaft is driven by a gear that mates with another gear attached to the crankshaft. [Figure 1-28] The camshaft always rotates at one-half the crankshaft speed. As the camshaft revolves, the lobes cause the tappet assembly to rise in the tappet guide, transmitting the force through the push rod and rocker arm to open the valve. [Figure 1-29]

**Tappet Assembly**

The tappet assembly consists of:

1. A cylindrical tappet, which slides in and out in a tappet guide installed in one of the crankcase sections around the cam ring;
2. A tappet roller, which follows the contour of the cam ring and lobes;
3. A tappet ball socket or push rod socket; and
4. A tappet spring.

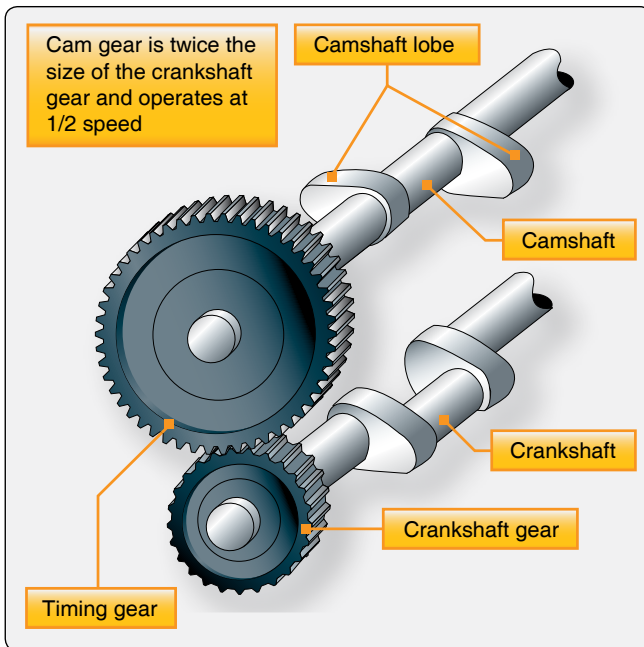

Figure 1-28. Cam drive mechanism opposed-type aircraft engine.

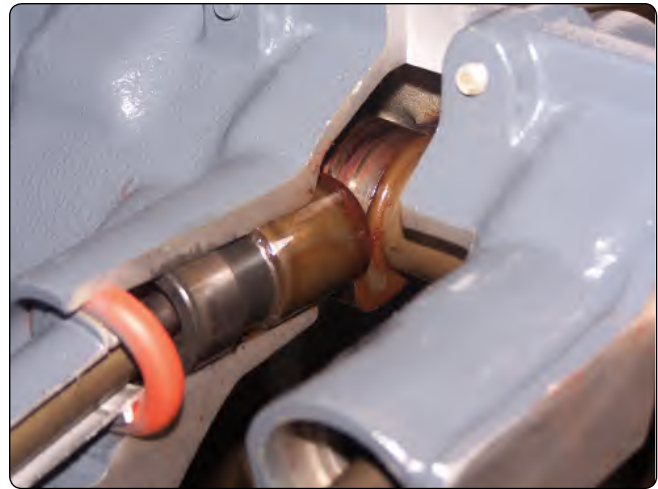

Figure 1-29. Cam load on lifter body.

The function of the tappet assembly is to convert the rotational movement of the cam lobe into reciprocating motion and to transmit this motion to the push rod, rocker arm, and then to the valve tip, opening the valve at the proper time. The purpose of the tappet spring is to take up the clearance between the rocker arm and the valve tip to reduce the shock load when the valve is opened. A hole is drilled through the tappet to allow engine oil to flow to the hollow push rods to lubricate the rocker assemblies.

**Solid Lifters/Tappets**

Solid lifters or cam followers generally require the valve clearance to be adjusted manually by adjusting a screw and lock nut. Valve clearance is needed to assure that the valve has enough clearance in the valve train to close completely. This adjustment or inspection was a continuous maintenance item until hydraulic lifters were used.

**Hydraulic Valve Tappets/Lifters**

Some aircraft engines incorporate hydraulic tappets that automatically keep the valve clearance at zero, eliminating the necessity for any valve clearance adjustment mechanism. A typical hydraulic tappet (zero-lash valve lifter) is shown in Figure 1-30.

When the engine valve is closed, the face of the tappet body (cam follower) is on the base circle or back of the cam. [Figure 1-30] The light plunger spring lifts the hydraulic plunger so that its outer end contacts the push rod socket, exerting a light pressure against it, thus eliminating any clearance in the valve linkage. As the plunger moves outward, the ball check valve moves off its seat. Oil from the supply chamber, which is directly connected with the engine lubrication system, flows in and fills the pressure chamber. As the camshaft rotates, the cam pushes the tappet body and the

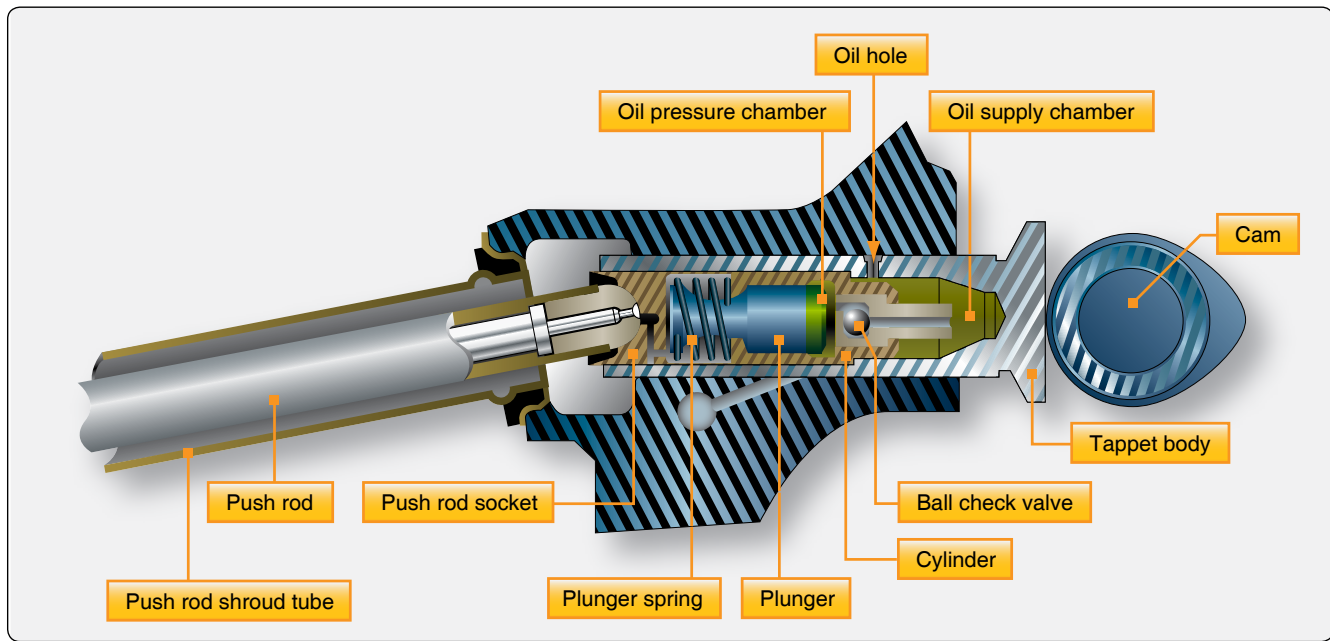

**Figure 1-30.** Hydraulic valve tappets.

hydraulic lifter cylinder outward. This action forces the ball check valve onto its seat; thus, the body of oil trapped in the pressure chamber acts as a cushion. During the interval when the engine valve is off its seat, a predetermined leakage occurs between plunger and cylinder bore, which compensates for any expansion or contraction in the valve train. Immediately after the engine valve closes, the amount of oil required to fill the pressure chamber flows in from the supply chamber, preparing for another cycle of operation.

Hydraulic valve lifters are normally adjusted at the time of overhaul. They are assembled dry (no lubrication), clearances checked, and adjustments are usually made by using push rods of different lengths. A minimum and maximum valve clearance is established. Any measurement between these extremes is acceptable, but approximately half way between the extremes is desired. Hydraulic valve lifters require less maintenance, are better lubricated, and operate more quietly than the screw adjustment type.

### Push Rod

The push rod, tubular in form, transmits the lifting force from the valve tappet to the rocker arm. A hardened-steel ball is pressed over or into each end of the tube. One ball end fits into the socket of the rocker arm. In some instances, the balls are on the tappet and rocker arm, and the sockets are on the push rod. The tubular form is employed because of its lightness and strength. It permits the engine lubricating oil under pressure to pass through the hollow rod and the drilled ball ends to lubricate the ball ends, rocker-arm bearing, and valve-stem guide. The push rod is enclosed in a tubular housing that extends from the crankcase to the cylinder head, referred to

as push rod tubes.

### Rocker Arms

The rocker arms transmit the lifting force from the cams to the valves. [Figure 1-31] Rocker arm assemblies are supported by a plain, roller, or ball bearing, or a combination of these, which serves as a pivot. Generally, one end of the arm bears against the push rod and the other bears on the valve stem. One end of the rocker arm is sometimes slotted to accommodate a steel roller. The opposite end is constructed with either a threaded split clamp and locking bolt or a tapped hole. The arm may have an adjusting screw, for adjusting the clearance between the rocker arm and the valve stem tip. The screw can be adjusted to the specified clearance to make certain that the valve closes fully.

### Valve Springs

Each valve is closed by two or three helical springs. If a single spring were used, it would vibrate or surge at certain speeds. To eliminate this difficulty, two or more springs (one inside the other) are installed on each valve. Each spring vibrates at a different engine speed and rapid damping out of all spring-surge vibrations during engine operation results. Two or more springs also reduce danger of weakness and possible failure by breakage due to heat and metal fatigue. The springs are held in place by split locks installed in the recess of the valve spring upper retainer or washer, and engage a groove machined into the valve stem. The functions of the valve springs are to close the valve and to hold the valve securely on the valve seat.



Figure 1-31. Rocker arms.

## Bearings

A bearing is any surface which supports, or is supported by, another surface. A good bearing must be composed of material that is strong enough to withstand the pressure imposed on it and should permit the other surface to move with a minimum of friction and wear. The parts must be held in position within very close tolerances to provide efficient and quiet operation, and yet allow freedom of motion. Lubricated bearings of many types are used to accomplish this, and at the same time reduce friction of moving parts so that power loss is not excessive and to prevent high oil temperatures caused by failed or failing bearings. Bearings are required to take radial loads, thrust loads, or a combination of the two. An example of a radial load would be a rotating shaft being held or contained in one position on a radial plane. Thrust load would be the rotating shaft being contained from moving axially along the shaft's axis. These radial and thrust loads are illustrated in *Figure 1-32*. There are two ways in which bearing surfaces move in relation to each other. One is by the sliding movement of one metal against the other (sliding friction), and the second is for one surface to roll over the other (rolling friction). The three different types of bearings in general use are plain, roller, and ball. [*Figure 1-33*]

## Plain Bearings

Plain bearings are generally used for the crankshaft, cam ring, camshaft, connecting rods, and the accessory drive shaft bearings. Such bearings are usually subjected to radial loads only, although some have been designed to take thrust loads. Plain bearings are usually made of nonferrous (having no iron) metals, such as silver, bronze, aluminum, and various alloys of copper, tin, or lead. Master rod or crankpin bearings in some engines are thin shells of steel, plated with silver on both the inside and the outside surfaces and with lead-tin plated over the silver on the inside surface only. Smaller bearings, such as those used to support various shafts in the accessory section, are called bushings. Porous Oilite bushings are widely used in this instance. They are impregnated with oil so that the heat of friction brings the oil to the bearing surface during engine operation.

## Ball Bearings

A ball bearing assembly consists of grooved inner and outer races, one or more sets of balls, in bearings designed for disassembly, and a bearing retainer. They are used for shaft bearings and rocker arm bearings in some reciprocating engines. Special deep-groove ball bearings are used to transmit propeller thrust and radial loads to the engine nose section of radial engines. Since this type of bearing can accept both radial and thrust loads, it is used in gas turbine engines to support one end of a shaft (radial loads) and to keep the shaft from moving axially (thrust loads).

## Roller Bearings

Roller bearings are made in many types and shapes, but the two types generally used in the aircraft engine are the straight roller and the tapered roller bearings. Straight roller bearings are used where the bearing is subjected to radial loads only. In tapered roller bearings, the inner- and outer-race bearing surfaces are cone-shaped. Such bearings withstand both radial and thrust loads. Straight roller bearings are used in high power reciprocating aircraft engines for the crankshaft main bearings. They are also used in gas turbine applications where radial loads are high. Generally, a rotating shaft in a gas turbine engine is supported by a deep-groove ball bearing

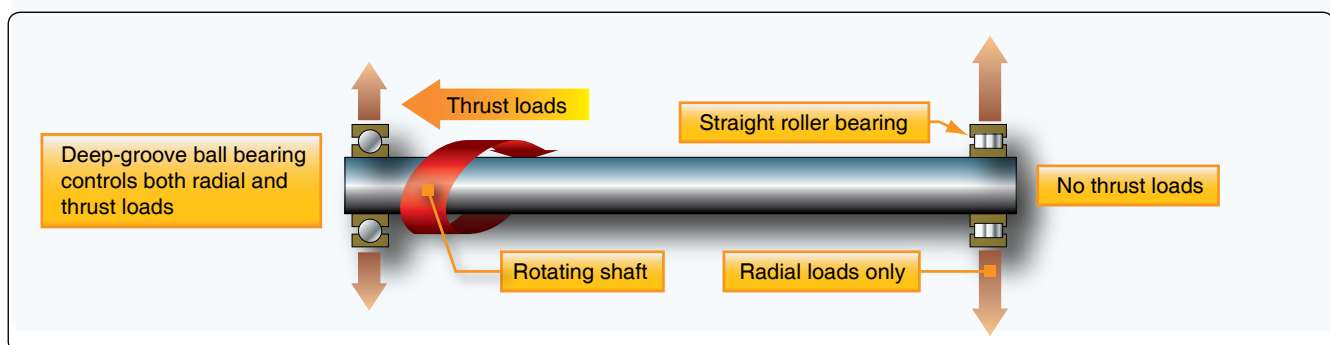
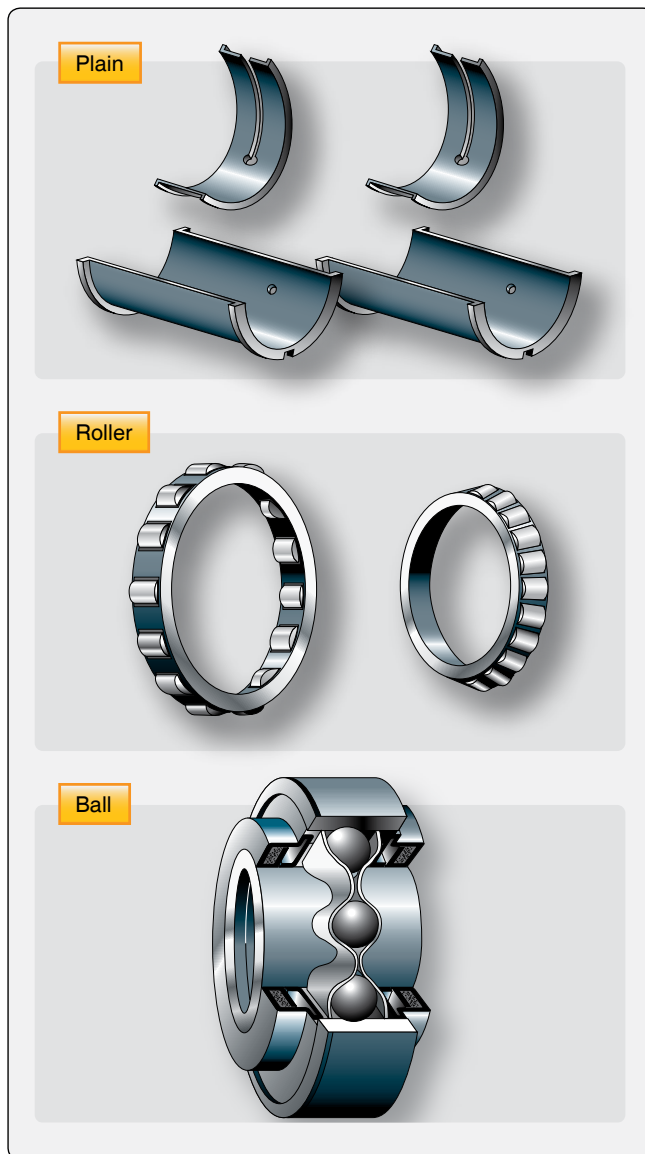

Figure 1-32. Radial and thrust loads.



**Figure 1-33.** Bearings.

(radial and thrust loads) on one end and a straight roller bearing (radial loads only) on the other end.

### Propeller Reduction Gearing

The increased brake horsepower delivered by a high horsepower engine results partly from increased crankshaft rpm. It is therefore necessary to provide reduction gears to limit the propeller rotation speed to a value at which efficient operation is obtained. Whenever the speed of the blade tips approaches the speed of sound, the efficiency of the propeller decreases rapidly. Reduction gearing for engines allows the engine to operate at a higher rpm, developing more power while slowing down the propeller rpm. This prevents the propeller efficiency from decreasing. Since reduction gearing must withstand extremely high stresses, the gears are machined from steel forgings. Many types of reduction gearing systems

are in use. The three types most commonly used are spur planetary, bevel planetary, and spur and pinion. [Figure 1-34]

The spur planetary reduction gearing consists of a large driving gear or sun gear splined (and sometimes shrunk) to the crankshaft, a large stationary gear, called a bell gear, and a set of small spur planetary pinion gears mounted on a carrier ring. The ring is fastened to the propeller shaft and the planetary gears mesh with both the sun gear and the stationary bell or ring gear. The stationary gear is bolted or splined to the front section housing. When the engine is operating, the sun gear rotates. Because the planetary gears are meshed with this ring, they also must rotate. Since they also mesh with the stationary gear, they walk or roll around it as they rotate, and the ring in which they are mounted rotates the propeller shaft in the same direction as the crankshaft but at a reduced speed.

In some engines, the bell gear is mounted on the propeller shaft, and the planetary pinion gear cage is held stationary. The sun gear is splined to the crankshaft and acts as a driving gear. In such an arrangement, the propeller travels at a reduced speed but in opposite direction to the crankshaft.

In the bevel planetary reduction gearing system, the driving gear is machined with beveled external teeth and is attached to the crankshaft. A set of mating bevel pinion gears is mounted in a cage attached to the end of the propeller shaft. The pinion gears are driven by the drive gear and walk around the stationary gear, which is bolted or splined to the front section housing. The thrust of the bevel pinion gears is absorbed by a thrust ball bearing of special design. The drive and the fixed gears are generally supported by heavy-duty ball bearings. This type of planetary reduction assembly is more compact than the other one described and, therefore, can be used where a smaller propeller gear step-down is desired. In the case of gas turbine turboprop engines, more than one stage of reduction gearing is used due to the high output speeds of the engine. Several types of lower powered engines can use the spur and pinion reduction gear arrangement.

### Propeller Shafts

Propeller shafts may be of three major types: tapered, splined, or flanged. Tapered shafts are identified by taper numbers. Splined and flanged shafts are identified by SAE numbers. The propeller shaft of most low power output engines is forged as part of the crankshaft. It is tapered, and a milled slot is provided so that the propeller hub can be keyed to the shaft. The keyway and key index of the propeller are in relation to the No. 1 cylinder top dead center. The end of the shaft is threaded to receive the propeller retaining nut. Tapered propeller shafts are common on older and smaller engines.

The propeller shaft of high-output radial engines is generally

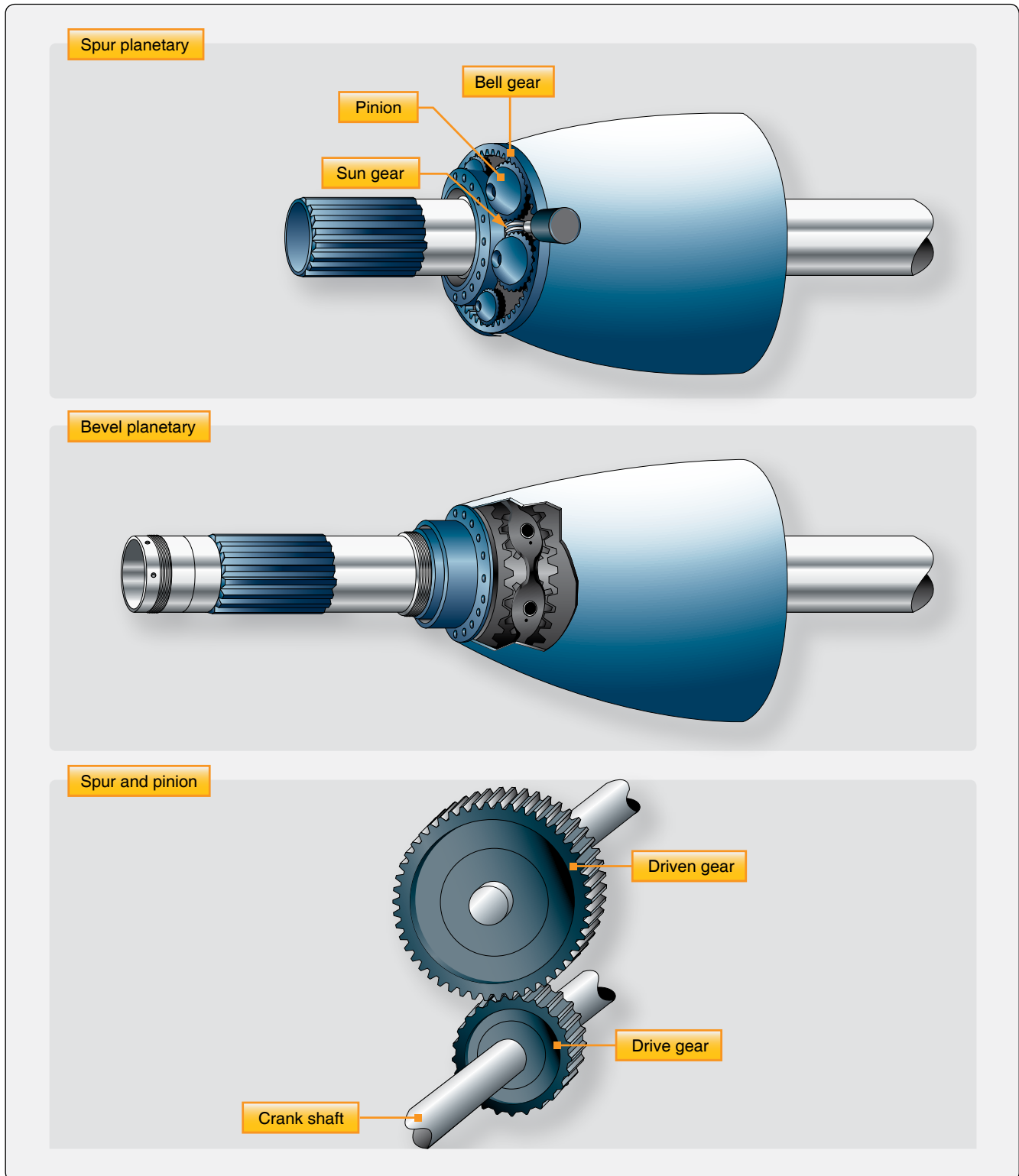

**Figure 1-34.** Reduction gears.

splined. It is threaded on one end for a propeller hub nut. The thrust bearing, which absorbs propeller thrust, is located around the shaft and transmits the thrust to the nose section housing. The shaft is threaded for attaching the thrust-bearing retaining nut. On the portion protruding from the housing

(between the two sets of threads), splines are located to receive the splined propeller hub. The shaft is generally machined from a steel-alloy forging throughout its length. The propeller shaft may be connected by reduction gearing to the engine crankshaft, but in smaller engines the propeller

shaft is simply an extension of the engine crankshaft. To turn the propeller shaft, the engine crankshaft must revolve.

Flanged propeller shafts are used on most modern reciprocating and turboprop engines. One end of the shaft is flanged with drilled holes to accept the propeller mounting bolts. The installation may be a short shaft with internal threading to accept the distributor valve to be used with a controllable propeller. The flanged propeller shaft is a very common installation on most propeller driven aircraft.

### Reciprocating Engine Operating Principles

The relationships between pressure, volume, and temperature of gases are the basic principles of engine operation. An internal combustion engine is a device for converting heat energy into mechanical energy. Gasoline is vaporized and mixed with air, forced or drawn into a cylinder, compressed by a piston, and then ignited by an electric spark. The conversion of the resultant heat energy into mechanical energy and then into work is accomplished in the cylinder. *Figure 1-35* illustrates the various engine components necessary to accomplish this conversion and also presents the principal terms used to indicate engine operation.

The operating cycle of an internal combustion reciprocating engine includes the series of events required to induct, compress, ignite, and burn, causing expansion of the air-fuel charge in the cylinder and to scavenge or exhaust the byproducts of the combustion process. When the compressed mixture is ignited, the resultant gases of combustion expand very rapidly and force the piston to move away from the cylinder head. This downward motion of the piston, acting on the crankshaft through the connecting rod, is converted to a circular or rotary motion by the crankshaft. A valve in the top or head of the cylinder opens to allow the burned gases to escape, and the momentum of the crankshaft and the propeller forces the piston back up in the cylinder where it is ready for the next event in the cycle. Another valve in the cylinder head then opens to let in a fresh charge of the air-fuel mixture. The valve allowing for the escape of the burning exhaust gases is called the exhaust valve, and the valve which lets in the fresh charge of the air-fuel mixture is called the intake valve. These valves are opened and closed mechanically at the proper times by the valve-operating mechanism. Therefore, the order of the five events of a four stroke cycle engine are intake, compression, ignition, power, and exhaust.

The bore of a cylinder is its inside diameter. The stroke is the distance the piston moves from one end of the cylinder to the other, specifically from top dead center (TDC) to bottom dead center (BDC), or vice versa. [*Figure 1-35*]

### Operating Cycles

There are several operating cycles in use:

1. Four stroke.
2. Two stroke.
3. Rotary.
4. Diesel.

### Four-Stroke Cycle

The vast majority of certified aircraft reciprocating engines operate on the four-stroke cycle, sometimes called the Otto cycle after its originator, a German physicist. The four-stroke cycle engine has many advantages for use in aircraft. One advantage is that it lends itself readily to high performance through supercharging.

In this type of engine, four strokes are required to complete the required series of events or operating cycle of each cylinder. [*Figure 1-36*] Two complete revolutions of the crankshaft (720°) are required for the four strokes; thus, each cylinder in an engine of this type fires once in every two revolutions of the crankshaft. In the following discussion of the four-stroke cycle engine operation, note that the timing of the ignition and

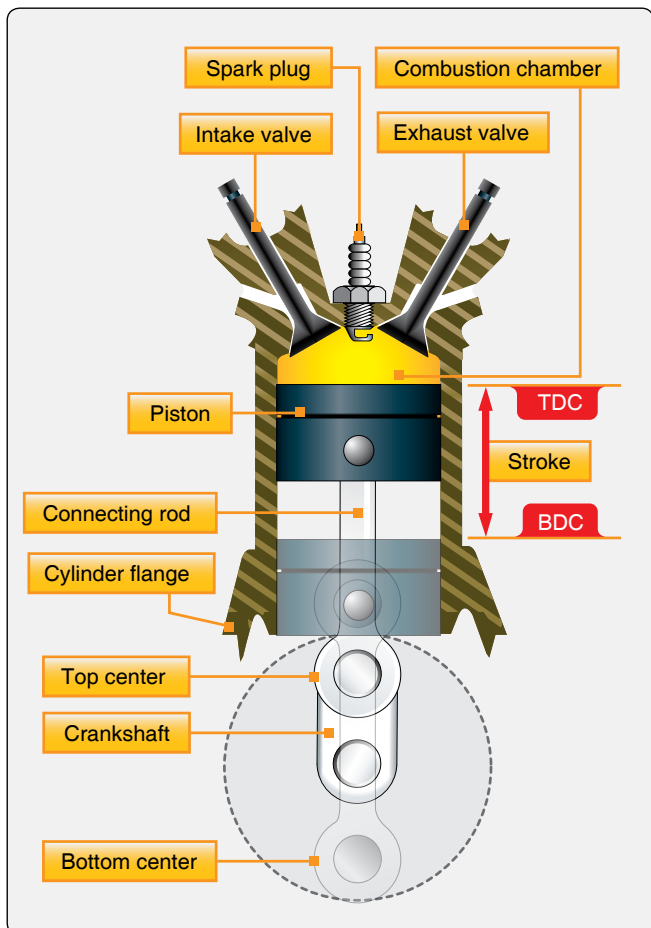

Figure 1-35. Components and terminology of engine operation.

the valve events vary considerably in different engines. Many factors influence the timing of a specific engine, and it is most important that the engine manufacturer’s recommendations in this respect be followed in maintenance and overhaul. The timing of the valve and ignition events is always specified in degrees of crankshaft travel. It should be remembered that a certain amount of crankshaft travel is required to open a valve fully; therefore, the specified timing represents the start of opening rather than the full-open position of the valve. An example valve timing chart can be seen in *Figure 1-37*.

**Intake Stroke**

During the intake stroke, the piston is pulled downward in the cylinder by the rotation of the crankshaft. This reduces the pressure in the cylinder and causes air under atmospheric pressure to flow through the carburetor, which meters the correct amount of fuel. The air-fuel mixture passes through the intake pipes and intake valves into the cylinders. The quantity or weight of the air-fuel charge depends upon the degree of throttle opening.

The intake valve is opened considerably before the piston

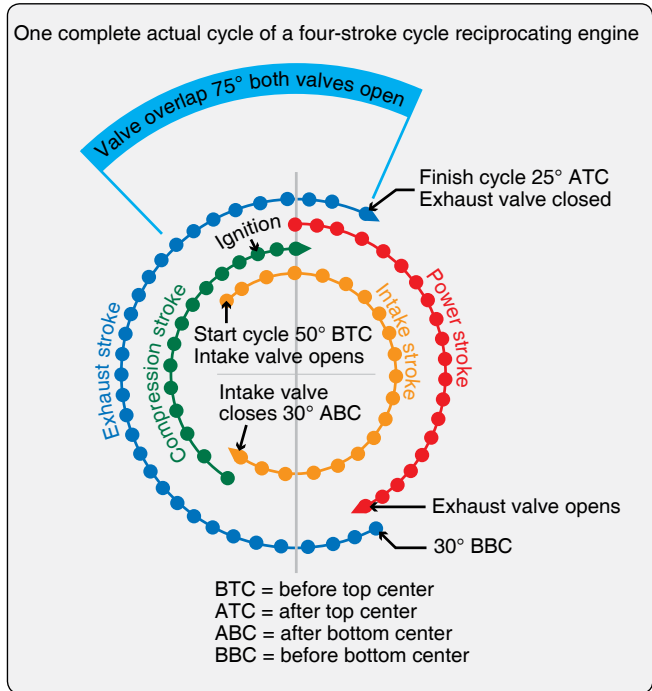

**Figure 1-37.** Valve timing chart.

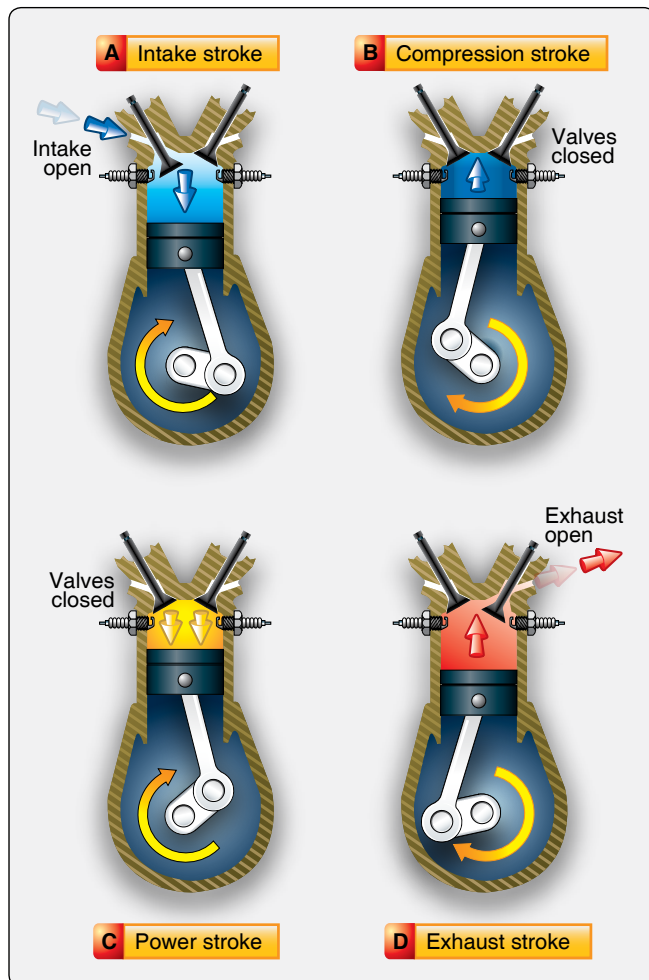

**Figure 1-36.** Four-stroke cycle.

reaches TDC on the exhaust stroke, in order to induce a greater quantity of the air-fuel charge into the cylinder and thus increase the horsepower. The distance the valve may be opened before TDC, however, is limited by several factors, such as the possibility that hot gases remaining in the cylinder from the previous cycle may flash back into the intake pipe and the induction system.

In all high-power aircraft engines, both the intake and the exhaust valves are off the valve seats at TDC at the start of the intake stroke. As mentioned above, the intake valve opens before TDC on the exhaust stroke (valve lead), and the closing of the exhaust valve is delayed considerably after the piston has passed TDC and has started the intake stroke (valve lag). This timing is called valve overlap and is designed to aid in cooling the cylinder internally by circulating the cool incoming air-fuel mixture, to increase the amount of the air-fuel mixture induced into the cylinder, and to aid in scavenging the byproducts of combustion from the cylinder.

The intake valve is timed to close about 50° to 75° past BDC on the compression stroke, depending upon the specific engine, to allow the momentum of the incoming gases to charge the cylinder more completely. Because of the comparatively large volume of the cylinder above the piston when the piston is near BDC, the slight upward travel of the piston during this time does not have a great effect on the incoming flow of gases. This late timing can be carried too far because the gases may be forced back through the intake valve and defeat the purpose of the late closing.

### **Compression Stroke**

After the intake valve is closed, the continued upward travel of the piston compresses the air-fuel mixture to obtain the desired burning and expansion characteristics. The charge is fired by means of an electric spark as the piston approaches TDC. The time of ignition varies from 20° to 35° before TDC, depending upon the requirements of the specific engine to ensure complete combustion of the charge by the time the piston is slightly past the TDC position.

Many factors affect ignition timing, and the engine manufacturer has expended considerable time in research and testing to determine the best setting. All engines incorporate devices for adjusting the ignition timing, and it is most important that the ignition system be timed according to the engine manufacturer's recommendations.

### **Power Stroke**

As the piston moves through the TDC position at the end of the compression stroke and starts down on the power stroke, it is pushed downward by the rapid expansion of the burning gases within the cylinder head with a force that can be greater than 15 tons (30,000 psi) at maximum power output of the engine. The temperature of these burning gases may be between 3,000 °F and 4,000 °F. As the piston is forced downward during the power stroke by the pressure of the burning gases exerted upon it, the downward movement of the connecting rod is changed to rotary movement by the crankshaft. Then, the rotary movement is transmitted to the propeller shaft to drive the propeller. As the burning gases are expanded, the temperature drops to within safe limits before the exhaust gases flow out through the exhaust port.

The timing of the exhaust valve opening is determined by, among other considerations, the desirability of using as much of the expansive force as possible and of scavenging the cylinder as completely and rapidly as possible. The valve is opened considerably before BDC on the power stroke (on some engines at 50° and 75° before BDC) while there is still some pressure in the cylinder. This timing is used so that the pressure can force the gases out of the exhaust port as soon as possible. This process frees the cylinder of waste heat after the desired expansion has been obtained and avoids overheating the cylinder and the piston. Thorough scavenging is very important, because any exhaust products remaining in the cylinder dilute the incoming air-fuel charge at the start of the next cycle.

### **Exhaust Stroke**

As the piston travels through BDC at the completion of the power stroke and starts upward on the exhaust stroke, it begins to push the burned exhaust gases out the exhaust port.

The speed of the exhaust gases leaving the cylinder creates a low pressure in the cylinder. This low or reduced pressure speeds the flow of the fresh air-fuel charge into the cylinder as the intake valve is beginning to open. The intake valve opening is timed to occur at 8° to 55° before TDC on the exhaust stroke on various engines.

### **Two-Stroke Cycle**

The two-stroke-cycle engine has re-emerged and is being used in ultra-light, light sport, and many experimental aircraft. As the name implies, two-stroke cycle engines require only one upstroke and one down stroke of the piston to complete the required series of events in the cylinder. Thus, the engine completes the operating cycle in one revolution of the crankshaft. The intake and exhaust functions are accomplished during the same stroke. These engines can be either air or water cooled and generally require a gear reduction housing between the engine and propeller.

### **Rotary Cycle**

The rotary cycle has a three-sided rotor that turns inside an elliptical housing, completing three of the four cycles for each revolution. These engines can be single rotor or multi-rotor and can be air or water cooled. They are used mostly with experimental and light aircraft. Vibration characteristics are also very low for this type of engine.

### **Diesel Cycle**

The diesel cycle depends on high compression pressures to provide for the ignition of the air-fuel charge in the cylinder. As air is drawn in the cylinder, it is compressed by a piston and, at maximum pressure, fuel is sprayed in the cylinder. At this point, the high pressure and temperature in the cylinder causes the fuel to burn increasing the internal pressure of the cylinder. This drives the piston down, turning or driving the crankshaft. Water and air cooled engines that can operate on JET A fuel (kerosene) use a version of the diesel cycle. There are many types of diesel cycles in use including two-stroke and four-stroke diesels.

## **Reciprocating Engine Power & Efficiencies**

All aircraft engines are rated according to their ability to do work and produce power. This section presents an explanation of work and power and how they are calculated. Also discussed are the various efficiencies that govern the power output of a reciprocating engine.

### **Work**

A physicist defines work as force times distance. Work done by a force acting on a body is equal to the magnitude of the force multiplied by the distance through which the force acts.

$$\text{Work (W)} = \text{Force (F)} \times \text{Distance (D)}$$

Work is measured by several standards. The most common unit is called foot-pound (ft-lb). If a one-pound mass is raised one foot, one ft-lb of work has been performed. The greater the mass is and/or the greater the distance is, the greater the work performed.

**Horsepower**

The common unit of mechanical power is the horsepower (hp). Late in the 18<sup>th</sup> century, James Watt, the inventor of the steam engine, found that an English workhorse could work at the rate of 550 ft-lb per second, or 33,000 ft-lb per minute, for a reasonable length of time. From his observations came the unit of horsepower, which is the standard unit of mechanical power in the English system of measurement. To calculate the hp rating of an engine, divide the power developed in ft-lb per minute by 33,000, or the power in ft-lb per second by 550.

$$\text{One hp} = \frac{\text{ft-lb per min}}{33,000}$$

or

$$\frac{\text{ft-lb per sec}}{550}$$

As stated above, work is the product of force and distance, and power is work per unit of time. Consequently, if a 33,000-lb weight is lifted through a vertical distance of 1 foot in 1 minute, the power expended is 33,000 ft-lb per minute, or exactly 1 hp.

Work is performed not only when a force is applied for lifting; force may be applied in any direction. If a 100-lb weight is dragged along the ground, a force is still being applied to perform work, although the direction of the resulting motion is approximately horizontal. The amount of this force would depend upon the roughness of the ground.

If the weight were attached to a spring scale graduated in pounds, then dragged by pulling on the scale handle, the amount of force required could be measured. Assume that the force required is 90 lb, and the 100-lb weight is dragged 660 feet in 2 minutes. The amount of work performed in the 2 minutes is 59,400 ft-lb or 29,700 ft-lb per minute. Since 1 hp is 33,000 ft-lb per minute, the hp expended in this case is 29,700 divided by 33,000, or 0.9 hp.

**Piston Displacement**

When other factors remain equal, the greater the piston displacement, the greater the maximum horsepower an engine is capable of developing. When a piston moves from BDC to TDC, it displaces a specific volume. The volume displaced by the piston is known as piston displacement and is expressed

in cubic inches for most American-made engines and cubic centimeters for others.

The piston displacement of one cylinder may be obtained by multiplying the area of the cross-section of the cylinder by the total distance the piston moves in the cylinder in one stroke. For multicylinder engines, this product is multiplied by the number of cylinders to get the total piston displacement of the engine.

Since the volume (V) of a geometric cylinder equals the area (A) of the base multiplied by the height (h), it is expressed mathematically as follows:

$$V = A \times h$$

The area of the base is the area of the cross-section of the cylinder.

**Area of a Circle**

To find the area of a circle, it is necessary to use a number called pi (π). This number represents the ratio of the circumference to the diameter of any circle. Pi cannot be stated exactly because it is a never-ending decimal. It is 3.1416 expressed to four decimal places, which is accurate enough for most computations.

The area of a circle, as in a rectangle or triangle, must be expressed in square units. The distance that is one-half the diameter of a circle is known as the radius. The area of any circle is found by squaring the radius (r) and multiplying by π. The formula is as follows:

$$A = \pi r^2$$

The radius of a circle is equal to ½ the diameter:

$$r = \frac{d}{2}$$

**Example**

Compute the piston displacement of the PWA 14 cylinder engine having a cylinder with a 5.5 inch diameter and a 5.5 inch stroke. Formulas required are:

$$r = \frac{d}{2}$$

$$A = \pi r^2$$

$$V = A \times h$$

$$\text{Total V} = V \times n \text{ (number of cylinders)}$$

Substitute values into these formulas and complete the calculation.

$$r = \frac{d}{2} = \frac{5.5 \text{ inches (in)}}{2} = 2.75 \text{ in}$$

$$A = \pi r^2 = 3.1416 (2.75 \text{ in} \times 2.75 \text{ in})$$

$$A = 3.1416 \times 7.5625 \text{ square inches (in}^2\text{)} = 23.7584 \text{ in}^2$$

$$V = A \times h = 23.7584 \text{ in}^2 \times 5.5 \text{ in} = 130.6712 \text{ cubic inches (in}^3\text{)}$$

$$\text{Total } V = V \times n = 130.6712 \text{ in}^3 \times 14$$

$$\text{Total } V = 1829.3968 \text{ in}^3$$

Rounded off to the next whole number, total piston displacement equals 1,829 cubic inches.

Another method of calculating the piston displacement uses the diameter of the piston instead of the radius in the formula for the area of the base.

$$A = \frac{1}{4} (\pi)(d^2)$$

$$\text{Substituting } A = \frac{1}{4} \times 3.1416 \times 5.5 \text{ in} \times 5.5 \text{ in}$$

$$A = 0.7854 \times 30.25 \text{ in}^2$$

$$A = 23.758 \text{ in}^2$$

From this point on, the calculations are identical to the preceding example.

### Compression Ratio

All internal combustion engines must compress the air-fuel mixture to receive a reasonable amount of work from each power stroke. The air-fuel charge in the cylinder can be compared to a coil spring in that the more it is compressed, the more work it is potentially capable of doing.

The compression ratio of an engine is a comparison of the volume of space in a cylinder when the piston is at the bottom of the stroke to the volume of space when the piston is at the top of the stroke. [Figure 1-38] This comparison is expressed as a ratio, hence the term compression ratio. Compression ratio is a controlling factor in the maximum horsepower developed by an engine, but it is limited by present day fuel grades and the high engine speeds and manifold pressures required for takeoff. For example, if there are 140 cubic inches of space in the cylinder when the piston is at the bottom and there are 20 cubic inches of space when the piston is at the top of the stroke, the compression ratio would be 140 to 20. If this ratio is expressed in fraction form, it would be 140/20 or 7 to 1, usually represented as 7:1.

The limitations placed on compression ratios, manifold pressure, and the manifold pressure's effect on compression

pressures has a major effect on engine operation. Manifold pressure is the average absolute pressure of the air or air-fuel charge in the intake manifold and is measured in units of inches of mercury ("Hg). Manifold pressure is dependent on engine speed (throttle setting) and the degree supercharging. The operation of the supercharger increases the weight of the charge entering the cylinder. When a true supercharger is used with the aircraft engine, the manifold pressure may be considerably higher than the pressure of the outside atmosphere. The advantage of this condition is that a greater amount of charge is forced into a given cylinder volume, and a greater output of horsepower results.

Compression ratio and manifold pressure determine the pressure in the cylinder in that portion of the operating cycle when both valves are closed. The pressure of the charge before compression is determined by manifold pressure, while the pressure at the height of compression (just prior to ignition) is determined by manifold pressure times the compression ratio. For example, if an engine were operating at a manifold pressure of 30 "Hg with a compression ratio of 7:1, the pressure at the instant before ignition would be approximately 210 "Hg. However, at a manifold pressure of 60 "Hg, the pressure would be 420 "Hg.

Without going into great detail, it has been shown that the compression event magnifies the effect of varying the manifold pressure, and the magnitude of both affects the pressure of the fuel charge just before the instant of ignition. If the pressure at this time becomes too high, pre-ignition or detonation occur and produce overheating. Pre-ignition is when the fuel air charge starts to burn before the spark plug fires. Detonation occurs when the fuel air charge is ignited by the spark plug, but instead of burning at a controlled rate, it explodes causing cylinder temperatures and pressures to spike very quickly. If this condition exists for very long, the engine can be damaged or destroyed.

One of the reasons for using engines with high compression ratios is to obtain long-range fuel economy, to convert more heat energy into useful work than is done in engines of low compression ratio. Since more heat of the charge is converted into useful work, less heat is absorbed by the cylinder walls. This factor promotes cooler engine operation, which in turn increases the thermal efficiency. Here again, a compromise is needed between the demand for fuel economy and the demand for maximum horsepower without detonation. Some manufacturers of high compression engines suppress detonation at high manifold pressures by using high octane fuel and limiting maximum manifold pressure.

**Indicated Horsepower**

The indicated horsepower produced by an engine is the horsepower calculated from the indicated mean effective pressure and the other factors which affect the power output of an engine. Indicated horsepower is the power developed in the combustion chambers without reference to friction losses within the engine. This horsepower is calculated as a function of the actual cylinder pressure recorded during engine operation.

To facilitate the indicated horsepower calculations, a mechanical indicating device, such as is attached to the engine cylinder, captures the actual pressure existing in the cylinder during the complete operating cycle. This pressure variation can be represented by the kind of graph shown in *Figure 1-39*. Notice that the cylinder pressure rises on the compression stroke, reaches a peak after top center, and decreases as the piston moves down on the power stroke. Since the cylinder pressure varies during the operating cycle, an average pressure (line AB) is computed. This average pressure, if applied steadily during the time of the power stroke, would do the same amount of work as the varying pressure during the same period. This average pressure is known as indicated mean effective pressure and is included in the indicated horsepower calculation with other engine specifications. If the characteristics and the indicated mean effective pressure of an engine are known, it is possible to calculate the indicated horsepower rating.

The indicated horsepower for a four-stroke cycle engine can be calculated from the following formula, in which the letter symbols in the numerator are arranged to spell the word “PLANK” to assist in memorizing the formula:

$$\text{Indicated horsepower} = \frac{\text{PLANK}}{33,000}$$

Where:

- P = Indicated mean effective pressure, in psi
- L = Length of the stroke, in feet or in fractions of a foot
- A = Area of the piston head or cross-sectional area of the cylinder, in square inches
- N = Number of power strokes per minute:  $\frac{\text{rpm}}{2}$
- K = Number of cylinders

In the formula above, the area of the piston multiplied by the indicated mean effective pressure gives the force acting on the piston in pounds. This force multiplied by the length of the stroke in feet gives the work performed in one power stroke, which, multiplied by the number of power strokes per minute, gives the number of ft-lb per minute of work produced by one cylinder. Multiplying this result by the number of cylinders in the engine gives the amount of work performed, in ft-lb, by the engine. Since hp is defined as work done at the rate of 33,000 ft-lb per minute, the total number of ft-lb of work performed by the engine is divided by 33,000 to find the indicated horsepower.

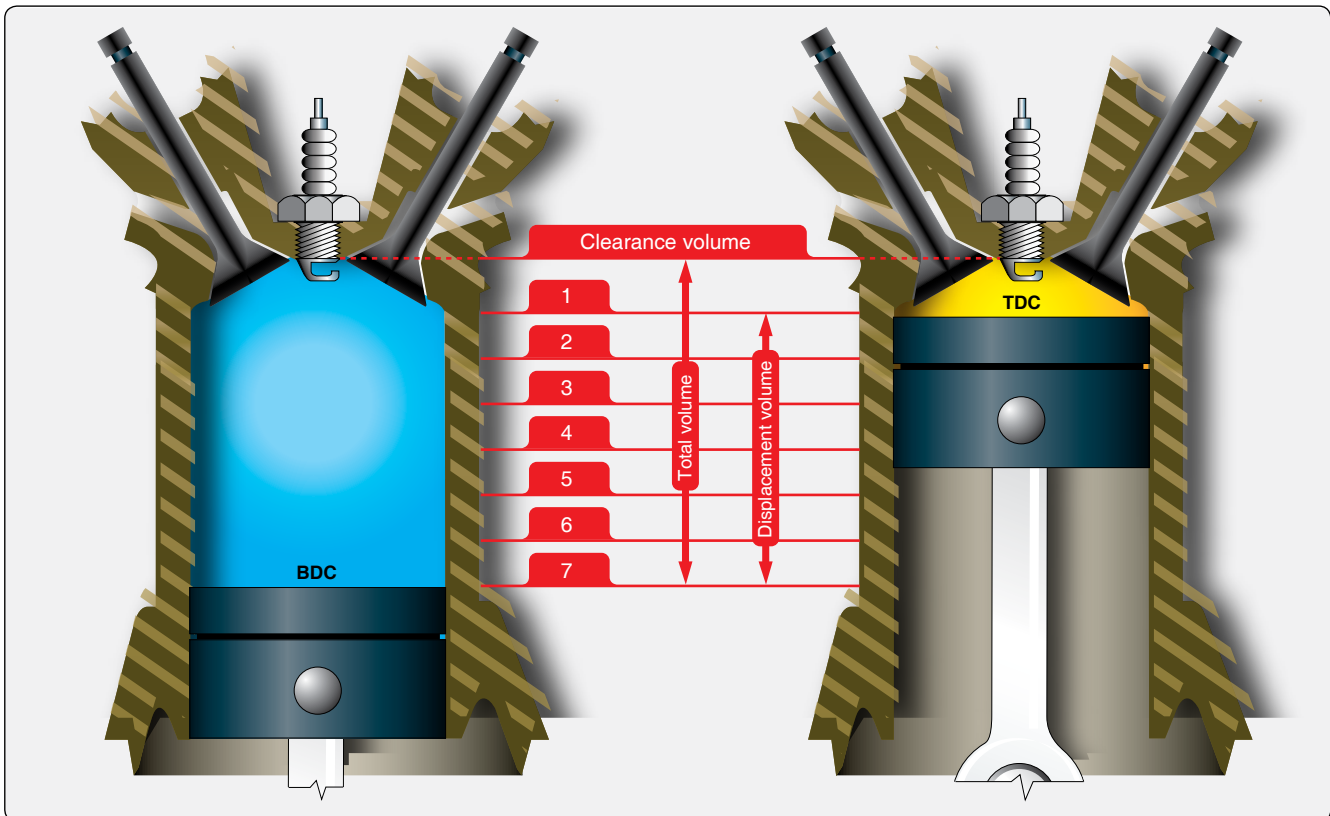

**Figure 1-38.** Compression ratio.

**Example**

Given:

$P = 1.65 \text{ lb/in}^2$   
 $L = 0.5 \text{ ft.}$   
 $A = 5.5 \text{ inches}$   
 $N = 1,500$   
 $K = 12$

Indicated hp =  $\frac{\text{PLANK}}{33,000 \text{ ft-lb/min}}$

Find indicated hp.

A is found by using the equation:  
 $A = \frac{1}{4}\pi D^2$   
 $A = \frac{1}{4} \times 3.1416 \times 5.5 \text{ in} \times 5.5 \text{ in}$   
 $= 23.76 \text{ in}^2$

N is found by multiplying the rpm by  $\frac{1}{2}$ :  
 $N = \frac{1}{2} \times 3,000 = 1,500 \text{ rpm}$

Now, substituting in the formula:  
 Indicated hp =  $\frac{1.65 \text{ lb/in}^2 \times 0.5 \text{ in} \times 23.76 \text{ in}^2 \times 1,500 \text{ rpm} \times 12}{33,000 \text{ ft-lb/min}}$   
 Indicated hp = 1,069.123

is the product of a force and the distance of the force from the axis about which it acts, or

Torque = force x distance  
(at right angles to the force)

Torque is a measure of load and is properly expressed in pound-inches (lb-in) or pound-feet (lb-ft). Torque should not be confused with work, which is expressed in inch-pounds (in-lb) or foot-pounds (ft-lb).

There are numerous devices for measuring torque, such as a dynamometer or a torque meter. One very simple type of device that can be used to demonstrate torque calculations is the Prony brake. [Figure 1-40] All of these torque-measuring devices are usable to calculate power output of an engine on a test stand. It consists essentially of a hinged collar, or brake, which can be clamped to a drum splined to the propeller shaft. The collar and drum form a friction brake, which can be adjusted by a wheel. An arm of a known length is rigidly attached to or is a part of the hinged collar and terminates at a point that rests on a set of scales. As the propeller shaft rotates, it tends to carry the hinged collar of the brake with it and is prevented from doing so only by the arm that rests on the scale. The scale indicates the force necessary to arrest the motion of the arm. If the resulting force registered on the scale is multiplied by the length of the arm, the resulting product is the torque exerted by the rotating shaft. For example, if the scale registers 200 pounds and the length of the arm is 3.18 feet, the torque exerted by the shaft is:

$200 \text{ lb} \times 3.18 \text{ ft} = 636 \text{ lb-ft}$

Once the torque is known, the work done per revolution of the propeller shaft can be computed without difficulty by the equation:

Work per revolution =  $2\pi \times \text{torque}$

**Brake Horsepower**

The indicated horsepower calculation discussed in the preceding paragraph is the theoretical power of a frictionless engine. The total horsepower lost in overcoming friction must be subtracted from the indicated horsepower to arrive at the actual horsepower delivered to the propeller. The power delivered to the propeller for useful work is known as brake horsepower (bhp). The difference between indicated and brake horsepower is known as friction horsepower, which is the horsepower required to overcome mechanical losses, such as the pumping action of the pistons, the friction of the pistons, and the friction of all other moving parts.

The measurement of an engine's bhp involves the measurement of a quantity known as torque or twisting moment. Torque

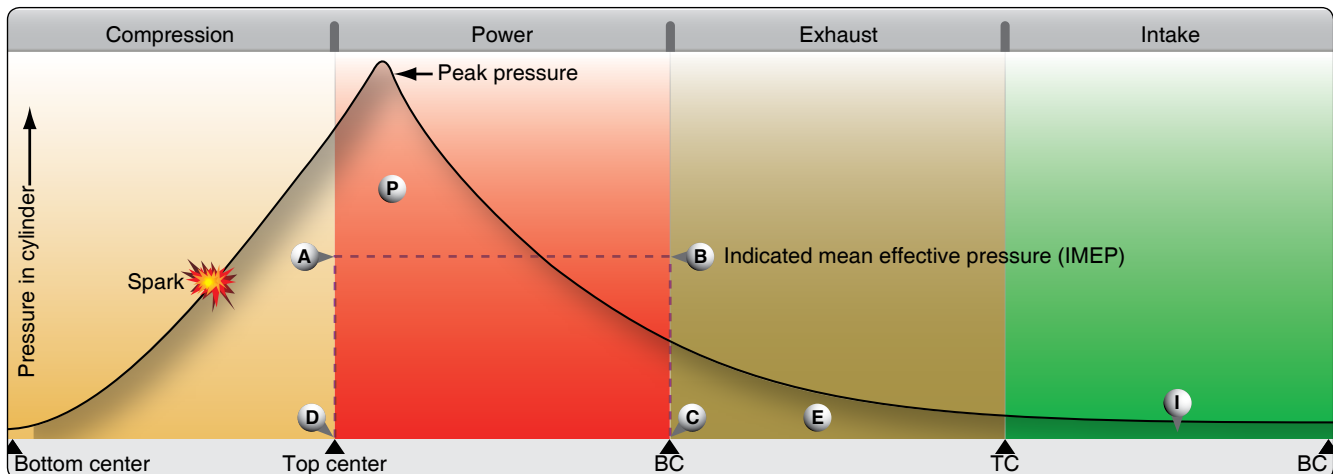

Figure 1-39. Compression ratio.

If work per revolution is multiplied by the rpm, the result is work per minute, or power. If the work is expressed in ft-lb per minute, this quantity is divided by 33,000. The result is the brake horsepower of the shaft.

$$\text{Power} = \text{Work per revolution} \times \text{rpm}$$

$$\text{bhp} = \frac{\text{Work per revolution} \times \text{rpm}}{33,000}$$

$$\frac{2\pi \times \text{force on scales (lb)} \times \text{length of arm (ft)} \times \text{rpm}}{33,000}$$

**Example**

Given:

Force on scales	= 200 lb
Length of arm	= 3.18 ft
rpm	= 3,000
$\pi$	= 3.1416

Find bhp substituting in equation:

$$\text{bhp} = \frac{6.2832 \times 200 \times 3.18 \times 3,000}{33,000}$$

$$= 363.2$$

$$= 363$$

the engine, but is not great enough to stop the engine, it is not necessary to know the amount of friction between the collar and drum to compute the bhp. If there were no load imposed, there would be no torque to measure, and the engine would “run away.” If the imposed load is so great that the engine stalls, there may be considerable torque to measure, but there is no rpm. In either case, it is impossible to measure the bhp of the engine. However, if a reasonable amount of friction exists between the brake drum and the collar and the load is then increased, the tendency of the propeller shaft to carry the collar and arm about with it becomes greater, thus imposing a greater force upon the scales. As long as the torque increase is proportional to the rpm decrease, the horsepower delivered at the shaft remains unchanged. This can be seen from the equation in which  $2\pi$  and 33,000 are constants and torque and rpm are variables. If the change in rpm is inversely proportional to the change in torque, their product remains unchanged, and bhp remains unchanged. This is important. It shows that horsepower is the function of both torque and rpm, and can be changed by changing either torque, rpm, or both.

**Friction Horsepower**

Friction horsepower is the indicated horsepower minus brake horsepower. It is the horsepower used by an engine in overcoming the friction of moving parts, drawing in fuel, expelling exhaust, driving oil and fuel pumps, and other engine accessories. On modern aircraft engines, this power loss through friction may be as high as 10 to 15 percent of

As long as the friction between the brake collar and propeller shaft drum is great enough to impose an appreciable load on

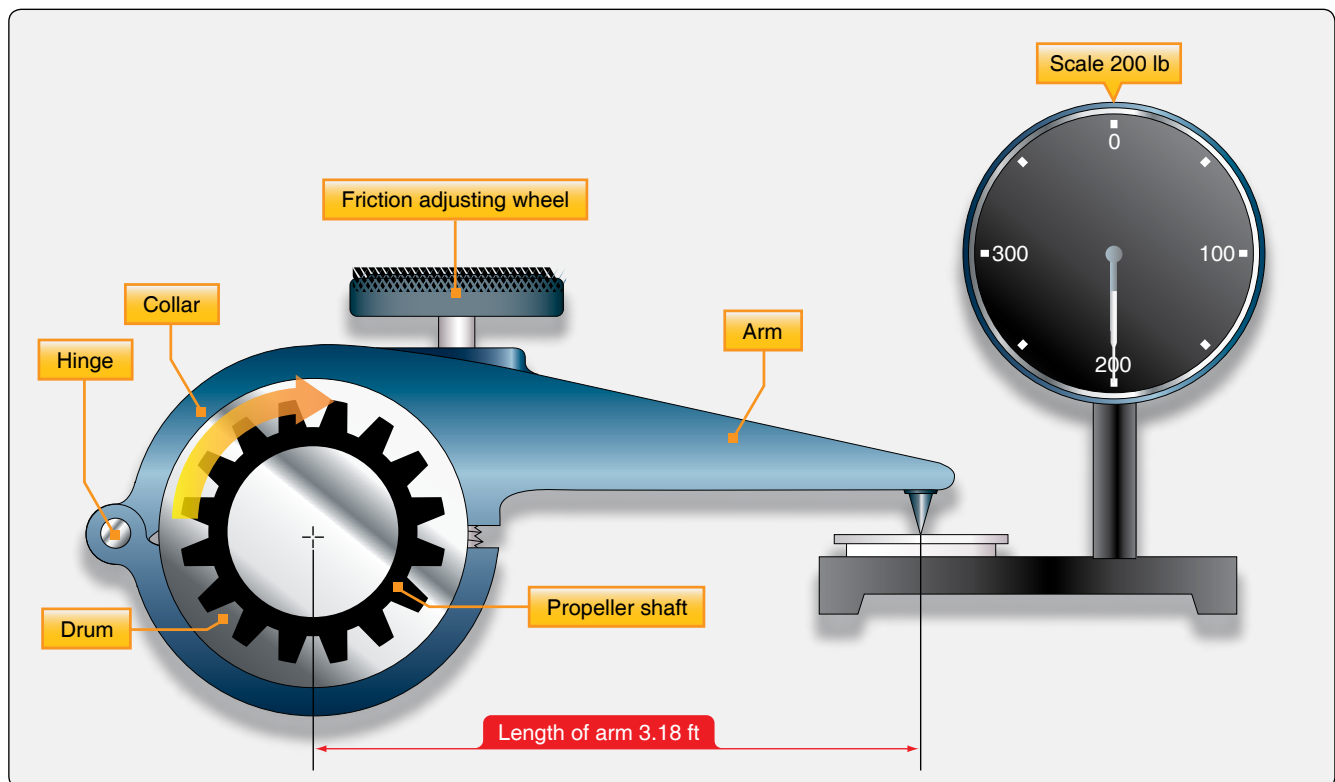

Figure 1-40. Typical Prony brake.

the indicated horsepower.

### Friction & Brake Mean Effective Pressures

The indicated mean effective pressure (IMEP), discussed previously, is the average pressure produced in the combustion chamber during the operating cycle and is an expression of the theoretical, frictionless power known as indicated horsepower. In addition to completely disregarding power lost to friction, indicated horsepower gives no indication of how much actual power is delivered to the propeller shaft for doing useful work. However, it is related to actual pressures that occur in the cylinder and can be used as a measure of these pressures.

To compute the friction loss and net power output, the indicated horsepower of a cylinder may be thought of as two separate powers, each producing a different effect. The first power overcomes internal friction, and the horsepower thus consumed is known as friction horsepower. The second power, known as brake horsepower, produces useful work at the propeller. That portion of IMEP that produces brake horsepower is called brake mean effective pressure (BMEP). The remaining pressure used to overcome internal friction is called friction mean effective pressure (FMEP). [Figure 1-41] IMEP is a useful expression of total cylinder power output, but is not a real physical quantity; likewise, FMEP and BMEP are theoretical but useful expressions of friction losses and net power output.

Although BMEP and FMEP have no real existence in the cylinder, they provide a convenient means of representing pressure limits or rating engine performance throughout its entire operating range. There is an operating relationship between IMEP, BMEP, and FMEP.

One of the basic limitations placed on engine operation is the pressure developed in the cylinder during combustion. In the discussion of compression ratios and indicated mean effective pressure, it was found that, within limits, increased pressure resulted in increased power. It was also noted that if the cylinder pressure were not controlled within close limits, it would impose dangerous internal loads that might result in engine failure. Therefore, it is important to have a means of determining these cylinder pressures as a protective measure and for efficient application of power.

If the bhp is known, the BMEP can be computed by means of the following equation:

$$\text{BMEP} = \frac{\text{bhp} \times 33,000}{\text{LANK}}$$

Given:

$$\text{bhp} = 1,000$$

$$\text{Stroke} = 6 \text{ in}$$

$$\text{Bore} = 5.5 \text{ in}$$

$$\text{rpm} = 3,000$$

$$\text{Number of cycles} = 12$$

Find BMEP:

Find length of stroke (in ft):

$$L = 6 \text{ in} = 0.5 \text{ ft}$$

Find area of cylinder bore:

$$A = \frac{1}{4}\pi D^2$$

$$A = \frac{1}{4} \times 3.1416 \times 5.5 \text{ in} \times 5.5 \text{ in}$$

$$A = 23.76 \text{ in}^2$$

Find number of power strokes per min:

$$N = \frac{1}{2} \times \text{rpm}$$

$$N = \frac{1}{2} \times 3,000$$

$$N = 1,500$$

Then, substituting in the equation:

$$\begin{aligned} \text{BMEP} &= \frac{1,000 \text{ bhp} \times 33,000 \text{ ft-lb/min}}{0.5 \text{ ft} \times 23.76 \text{ in}^2 \times 1,500 \text{ strokes/min} \times 12} \\ &= 154.32 \text{ lb/in}^2 \end{aligned}$$

### Thrust Horsepower

Thrust horsepower can be considered the result of the engine and the propeller working together. If a propeller could be designed to be 100 percent efficient, the thrust and the bhp would be the same. However, the efficiency of the propeller varies with the engine speed, attitude, altitude, temperature, and airspeed. Thus, the ratio of the thrust horsepower and the bhp delivered to the propeller shaft will never be equal. For example, if an engine develops 1,000 bhp, and it is used with a propeller having 85 percent efficiency, the thrust horsepower of that engine-propeller combination is 85 percent of 1,000 or 850 thrust hp. Of the four types of horsepower discussed, it is the thrust horsepower that determines the performance of the engine-propeller combination.

### Efficiencies

#### Thermal Efficiency

Any study of engines and power involves consideration of heat as the source of power. The heat produced by the burning of gasoline in the cylinders causes a rapid expansion of the gases in the cylinder, and this, in turn, moves the pistons

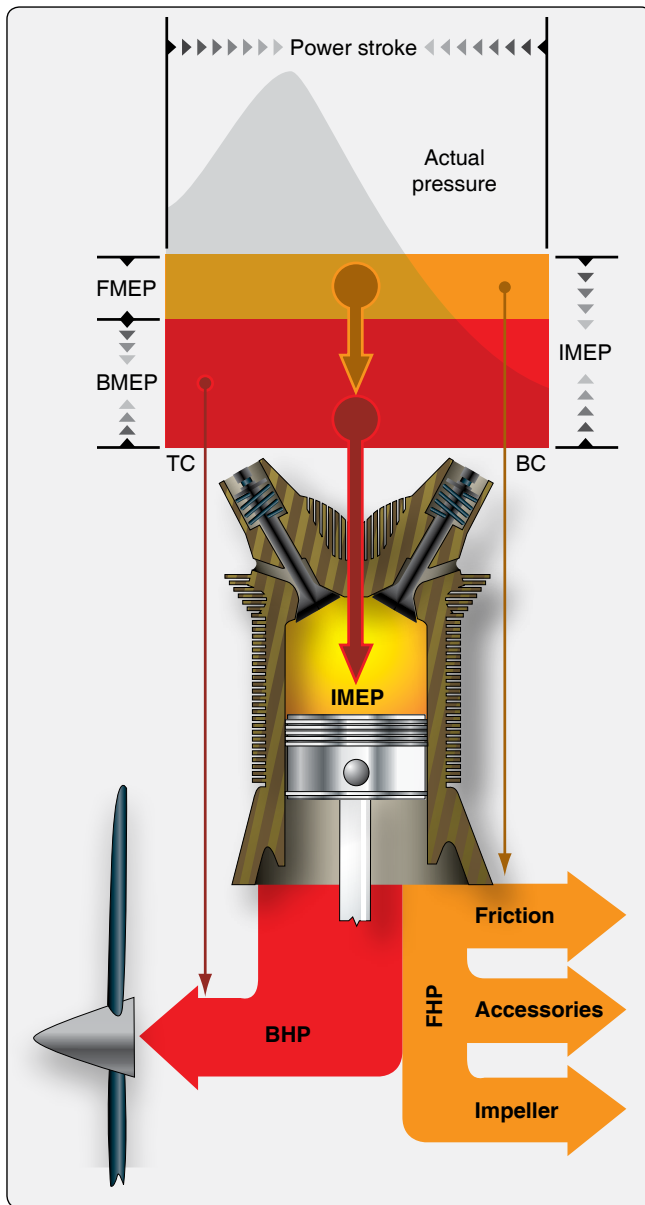

Figure 1-41. Power and pressure.

and creates mechanical energy. It has long been known that mechanical work can be converted into heat and that a given amount of heat contains the energy equivalent of a certain amount of mechanical work. Heat and work are theoretically interchangeable and bear a fixed relation to each other. Heat can therefore be measured in work units (for example, ft-lb) as well as in heat units. The British thermal unit (BTU) of heat is the quantity of heat required to raise the temperature of 1 pound of water by 1 °F. It is equivalent to 778 ft-lb of mechanical work. A pound of petroleum fuel, when burned with enough air to consume it completely, gives up about 20,000 BTU, the equivalent of 15,560,000 ft-lb of mechanical work. These quantities express the heat energy of the fuel in heat and work units, respectively.

The ratio of useful work done by an engine to the heat

energy of the fuel it uses, expressed in work or heat units, is called the thermal efficiency of the engine. If two similar engines use equal amounts of fuel, the engine that converts into work the greater part of the energy in the fuel (higher thermal efficiency) delivers the greater amount of power. Furthermore, the engine that has the higher thermal efficiency has less waste heat to dispose of to the valves, cylinders, pistons, and cooling system of the engine. A high thermal efficiency also means low specific fuel consumption and, therefore, less fuel for a flight of a given distance at a given power. Thus, the practical importance of a high thermal efficiency is threefold, and it constitutes one of the most desirable features in the performance of an aircraft engine.

Of the total heat produced, 25 to 30 percent is utilized for power output, 15 to 20 percent is lost in cooling (heat radiated from cylinder head fins), 5 to 10 percent is lost in overcoming friction of moving parts; and 40 to 45 percent is lost through the exhaust. Anything that increases the heat content going into mechanical work on the piston, which reduces the friction and pumping losses, or which reduces the quantity of unburned fuel or the heat lost to the engine parts, increases the thermal efficiency.

The portion of the total heat of combustion that is turned into mechanical work depends to a great extent upon the compression ratio. The compression ratio is the ratio of the piston displacement plus combustion chamber space to the combustion chamber space, as mentioned earlier. Other things being equal, the higher the compression ratio is, the larger is the proportion of the heat energy of combustion turned into useful work at the crankshaft. On the other hand, increasing the compression ratio increases the cylinder head temperature. This is a limiting factor because the extremely high temperature created by high compression ratios causes the material in the cylinder to deteriorate rapidly and the fuel to detonate instead of burning at a controlled rate.

The thermal efficiency of an engine may be based on either bhp or indicated horsepower (ihp) and is represented by the following formula:

$$\text{Indicated thermal efficiency} = \frac{\text{ihp} \times 33,000}{\text{weight of fuel burned/min.} \times \text{heat value} \times 778}$$

The formula for brake thermal efficiency is the same as shown above, except the value for bhp is inserted instead of the value for ihp.

**Example**

An engine delivers 85 bhp for a period of 1 hour and during that time consumes 50 pounds of fuel. Assuming the fuel has

a heat content of 18,800 BTU per pound, find the thermal efficiency of the engine:

$$\frac{8.5 \text{ ihp} \times 33,000}{0.833 \times 18,800 \text{ BTU} \times 778} = \frac{2,805,000}{12,184,569}$$

Brake thermal efficiency = 0.23 or 23 percent

Reciprocating engines are only about 34 percent thermally efficient; that is, they transform only about 34 percent of the total heat potential of the burning fuel into mechanical energy. The remainder of the heat is lost through the exhaust gases, the cooling system, and the friction within the engine. Thermal distribution in a reciprocating engine is illustrated in *Figure 1-42*.

**Mechanical Efficiency**

Mechanical efficiency is the ratio that shows how much of the power developed by the expanding gases in the cylinder is actually delivered to the output shaft. It is a comparison between the bhp and the ihp. It can be expressed by the following formula:

$$\text{Mechanical efficiency} = \frac{\text{bhp}}{\text{ihp}}$$

Brake horsepower is the useful power delivered to the propeller shaft. Indicated horsepower is the total hp developed in the cylinders. The difference between the two is friction horsepower (fhp), the power lost in overcoming friction. The factor that has the greatest effect on mechanical efficiency is the friction within the engine itself. The friction between moving parts in an engine remains practically constant throughout an engine’s speed range. Therefore, the mechanical efficiency of an engine is highest when the engine is running at the rpm at which maximum bhp is developed. Mechanical efficiency of the average aircraft reciprocating engine approaches 90 percent.

**Volumetric Efficiency**

Volumetric efficiency is a ratio expressed in terms of percentages. It is a comparison of the volume of air-fuel charge (corrected for temperature and pressure) inducted into the cylinders to the total piston displacement of the engine. Various factors cause departure from a 100 percent volumetric efficiency. The pistons of a naturally aspirated engine displace the same volume each time they travel from top center to bottom center of the cylinders. The amount of charge that fills this volume on the intake stroke depends on the existing pressure and temperature of the surrounding atmosphere. Therefore, to find the volumetric efficiency of an engine, standards for atmospheric pressure and temperature had to be established. The U.S. standard atmosphere was established in 1958, and provides the necessary pressure and temperature values to calculate volumetric efficiency.

The standard sea level temperature is 59 °F, or 15 °C. At this temperature, the pressure of one atmosphere is 14.69 lb/in<sup>2</sup>, and this pressure supports a column of mercury (Hg) 29.92 inches high, or 29.92 "Hg. These standard sea level conditions determine a standard density, and if the engine draws in a volume of charge of this density exactly equal to its piston displacement, it is said to be operating at 100 percent volumetric efficiency. An engine drawing in less volume than this has a volumetric efficiency lower than 100 percent. An engine equipped with true supercharging (boost above 30.00 "Hg) may have a volumetric efficiency greater than 100 percent. The equation for volumetric efficiency is as follows:

$$\text{Volumetric efficiency} = \frac{\text{Volume of charge (corrected for temperature and pressure)}}{\text{Piston displacement}}$$

Many factors decrease volumetric efficiency, including:

- Part-throttle operation;
- Long intake pipes of small diameter;
- Sharp bends in the induction system;

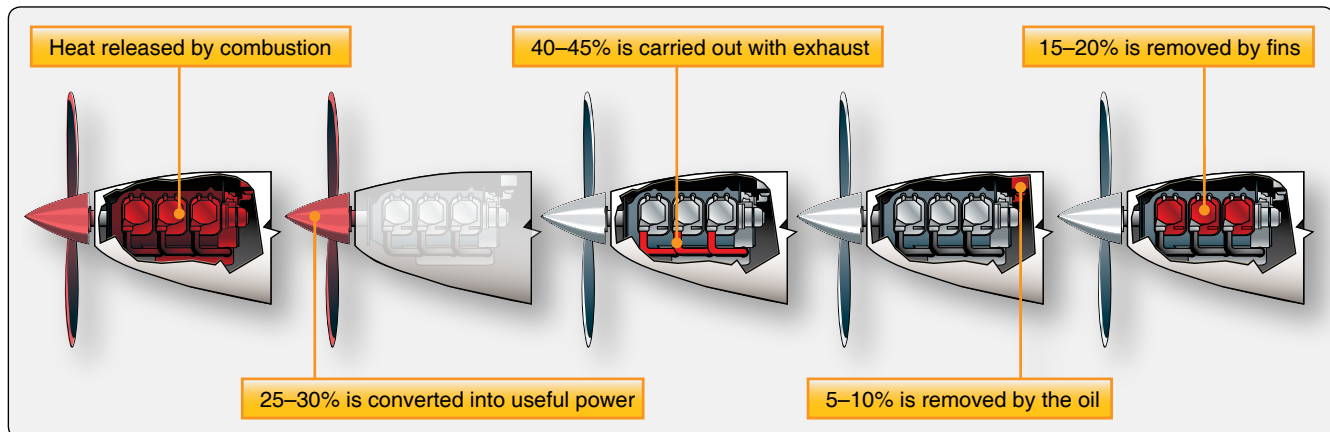

Figure 1-42. Thermal distribution in an engine.

- Carburetor air temperature too high;
- Cylinder-head temperature too high;
- Incomplete scavenging; and
- Improper valve timing.

### Propulsive Efficiency

A propeller is used with an engine to provide thrust. The engine supplies bhp through a rotating shaft, and the propeller absorbs the bhp and converts it into thrust hp. In this conversion, some power is wasted. Since the efficiency of any machine is the ratio of useful power output to the power input, propulsive efficiency (in this case, propeller efficiency) is the ratio of thrust hp to bhp. On the average, thrust hp constitutes approximately 80 percent of the bhp. The other 20 percent is lost in friction and slippage. Controlling the blade angle of the propeller is the best method of obtaining maximum propulsive efficiency for all conditions encountered in flight.

During takeoff, when the aircraft is moving at low speeds and when maximum power and thrust are required, a low propeller blade angle gives maximum thrust. For high-speed flying or diving, the blade angle is increased to obtain maximum thrust and efficiency. The constant-speed propeller is used to give required thrust at maximum efficiency for all flight conditions.

## Gas Turbine Engines

### Types & Construction

In a reciprocating engine, the functions of intake, compression, combustion, and exhaust all take place in the same combustion chamber. Consequently, each must have exclusive occupancy of the chamber during its respective part of the combustion cycle. A significant feature of the gas turbine engine is that separate sections are devoted to each function, and all functions are performed simultaneously without interruption.

A typical gas turbine engine consists of:

1. An air inlet,
2. Compressor section,
3. Combustion section,
4. Turbine section,
5. Exhaust section,
6. Accessory section, and
7. The systems necessary for starting, lubrication, fuel supply, and auxiliary purposes, such as anti-icing, cooling, and pressurization.

The major components of all gas turbine engines are basically the same; however, the nomenclature of the component

parts of various engines currently in use varies slightly due to the difference in each manufacturer's terminology. These differences are reflected in the applicable maintenance manuals. One of the greatest single factors influencing the construction features of any gas turbine engine is the type of compressor or compressors for which the engine is designed.

Four types of gas turbine engines are used to propel and power aircraft. They are the turbofan, turboprop, turboshaft, and turbojet. The term "turbojet" was used to describe any gas turbine engine used in aircraft. As gas turbine technology evolved, these other engine types were developed to take the place of the pure turbojet engine. The turbojet engine has problems with noise and fuel consumption in the speed range that airliners fly (.8 Mach). Due to these problems, use of pure turbojet engines is very limited. So, almost all airliner-type aircraft use a turbofan engine. It was developed to turn a large fan or set of fans at the front of the engine and produces about 80 percent of the thrust from the engine. This engine was quieter and had better fuel consumption in this speed range. Turbofan engines have more than one shaft in the engine; many are two-shaft engines. This means that there are two sets of compressors and turbines that drive them. These two-shafted engines use two spools (a spool is a compressor and a shaft and turbines that drive that compressor). In a two-spool engine, there is a high-pressure spool and a low-pressure spool. The low-pressure spool generally contains the fan(s) and the turbine stages it takes to drive them. The high-pressure spool is the high-pressure compressor, shaft, and turbines. This spool makes up the core of the engine, and this is where the combustion section is located.

Turbofan engines can be low bypass or high bypass. The amount of air that is bypassed around the core of the engine determines the bypass ratio. As can be seen in *Figure 1-43*, the air generally driven by the fan does not pass through the internal working core of the engine. The amount of air flow in lb/sec from the fan bypass to the core flow of the engine is the bypass ratio.

$$\text{Bypass ratio} = \frac{100 \text{ lb/sec flow fan}}{20 \text{ lb/sec flowcore}} = 5:1 \text{ bypass ratio}$$

Some low-bypass turbofan engines are used in speed ranges above .8 Mach (military aircraft). These engines use augmenters or afterburners to increase thrust. By adding more fuel nozzles and a flame holder in the exhaust system extra fuel can be sprayed and burned which can give large increases in thrust for short amounts of time.

The turboprop engine is a gas turbine engine that turns a propeller through a speed reduction gear box. This type of engine is most efficient in the 300 to 400 mph speed range and

can use shorter runways than other aircraft. Approximately 80 to 85 percent of the energy developed by the gas turbine engine is used to drive the propeller. The rest of the available energy exits the exhaust as thrust. By adding the horsepower developed by the engine shaft and the horsepower in the exiting thrust, the answer is equivalent shaft horsepower.

With regard to aircraft, the turboshaft engine is a gas turbine engine made to transfer horsepower to a shaft that turns a helicopter transmission or is an onboard auxiliary power unit (APU). An APU is used on turbine-powered aircraft to provide electrical power and bleed air on the ground and a backup generator in flight. Turboshaft engines can come in many different styles, shapes, and horsepower ranges.

### Air Entrance

The air entrance is designed to conduct incoming air to the compressor with a minimum energy loss resulting from drag or ram pressure loss; that is, the flow of air into the compressor should be free of turbulence to achieve maximum operating efficiency. Proper inlet design contributes materially to aircraft performance by increasing the ratio of compressor discharge pressure to duct inlet pressure.

This is also referred to as the compressor pressure ratio. This ratio is the outlet pressure divided by the inlet pressure. The amount of air passing through the engine is dependent upon three factors:

1. The compressor speed (rpm).
2. The forward speed of the aircraft.
3. The density of the ambient (surrounding) air.

Turbine inlet type is dictated by the type of gas turbine engine. A high-bypass turbofan engine inlet is completely different from a turboprop or turboshaft inlet. Large gas turbine-powered aircraft almost always have a turbofan engine. The inlet on this type of engine is bolted to the front (A flange) of the engine. These engines are mounted on the wings, or nacelles, on the aft fuselage, and a few are in the vertical fin. A typical turbofan inlet can be seen in *Figure 1-44*. Since on most modern turbofan engines the huge fan is the first part of the aircraft the incoming air comes into contact with, icing protection must be provided. This prevents chunks of ice from forming on the leading edge of the inlet, breaking loose, and damaging the fan. Warm air is bled from the engine's compressor and is ducted through the inlet to prevent ice from forming. If inlet guide vanes are used to straighten the air flow, then they also have anti-icing air flowing through them. The inlet also contains some sound-reducing materials that absorb the fan noise and make the engine quieter.

Turboprops and turboshafts can use an inlet screen to help filter out ice or debris from entering the engine. A deflector vane and a heated inlet lip are used to prevent ice from forming and allowing large chunks to enter the engine.

On military aircraft, the divided entrance permits the use of very short ducts with a resultant small pressure drop through skin friction. Military aircraft can fly at speeds above Mach 1, but the airflow through the engine must always stay below Mach 1. Supersonic air flow in the engine would destroy the engine. By using convergent and divergent shaped ducts, the air flow is controlled and dropped to subsonic speeds before entering the engine. Supersonic inlets are used to slow the incoming engine air to less than Mach 1 before it enters the engine.

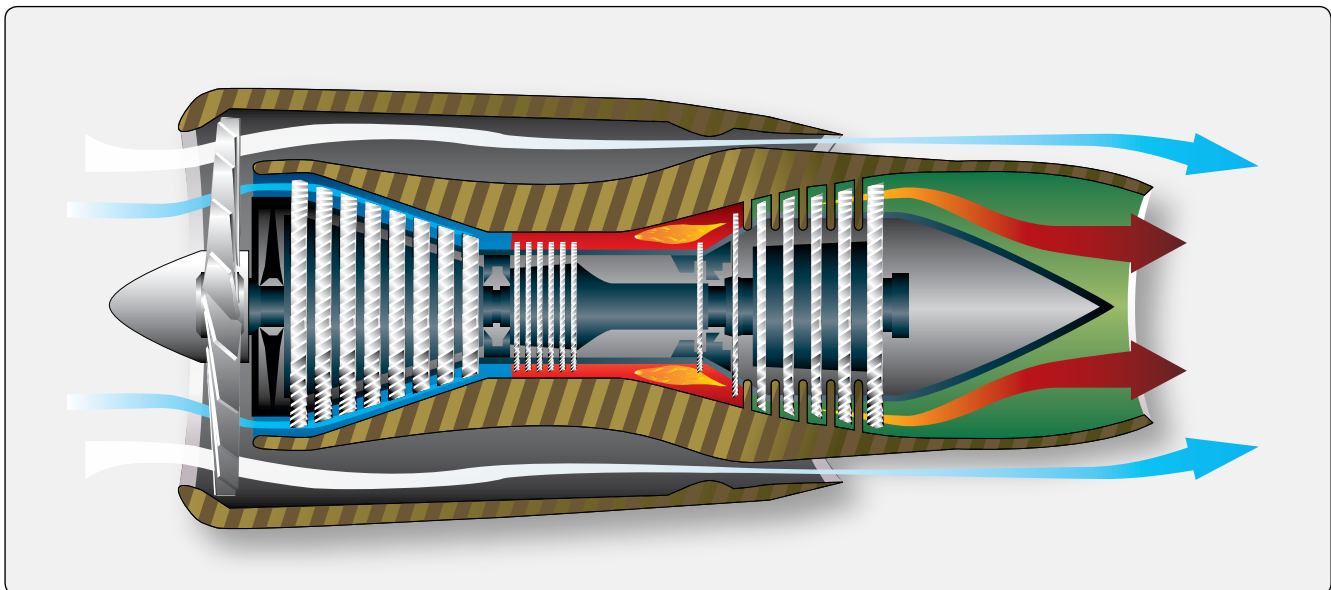

**Figure 1-43.** Turbofan engine with separate nozzles, fan, and core.

## Accessory Section

The accessory section of the gas turbine engine has various functions. The primary function is to provide space for the mounting of accessories necessary for operation and control of the engine. Generally, it also includes accessories concerned with the aircraft, such as electric generators and hydraulic pumps. Secondary functions include acting as an oil reservoir and/or oil sump and housing the accessory drive gears and reduction gears.

The arrangement and driving of accessories has always been a major problem on gas turbine engines. Driven accessories on turboprops are usually mounted on the accessory gear box, which is on the bottom of the engine. The location of the accessory gear box varies somewhat, but most turboprops and turboshafts have the accessory cases mounted to the back section of the engine.

The components of the accessory section of all gas turbine engines have essentially the same purpose, even though they often differ quite extensively in construction details and nomenclature.

The basic elements of the accessory section are:

1. The accessory case, which has machined mounting pads for the engine-driven accessories, and
2. The gear train, which is housed within the accessory case.

The accessory case may be designed to act as an oil reservoir. If an oil tank is utilized, a sump is usually provided below the front bearing support for the drainage and scavenging of oil used to lubricate bearings and drive gears. The accessory case is also provided with adequate tubing or cored passages for spraying lubricating oil on the gear train and supporting bearings.

The gear train is driven by the engine high-pressure compressor through an accessory drive shaft (tower shaft) gear coupling, which splines with a gear box gear and the high-pressure compressor. The reduction gearing within the case provides suitable drive speeds for each engine accessory or component. Because the rotor operating rpm is so high, the accessory reduction gear ratios are relatively high. The accessory drives are supported by ball bearings assembled in the mounting pad bores of the accessory case. *[Figure 1-45]*

## Compressor Section

The compressor section of the gas turbine engine has many functions. Its primary function is to supply air in sufficient quantity to satisfy the requirements of the combustion burners. Specifically, to fulfill its purpose, the compressor must increase the pressure of the mass of air received from

the air inlet duct, and then discharge it to the burners in the quantity and at the pressures required.

A secondary function of the compressor is to supply bleed-air for various purposes in the engine and aircraft. The bleed-air is taken from any of the various pressure stages of the compressor. The exact location of the bleed ports is, of course, dependent on the pressure or temperature required for a particular job. The ports are small openings in the compressor case adjacent to the particular stage from which the air is to be bled; thus, varying degrees of pressure are available simply by tapping into the appropriate stage. Air is often bled from the final or highest pressure stage since, at this point, pressure and air temperature are at a maximum. At times it may be necessary to cool this high-pressure air. If it is used for cabin pressurization or other purposes to which excess heat would be uncomfortable or detrimental, the air is sent through an air conditioning unit before it enters the cabin.

Bleed air is utilized in a wide variety of ways. Some of the current applications of bleed air are:

1. Cabin pressurization, heating, and cooling;
2. Deicing and anti-icing equipment;
3. Pneumatic starting of engines; and
4. Auxiliary drive units (ADU).

Another function of the compressor bleed air is for the operation of vortex dissipaters. The vortex dissipater supplies a high-velocity stream of compressor bleed air blown from a nozzle into an area where vortices are likely to form. Vortex dissipaters destroy the vortices that would otherwise suck debris from the ground into engines mounted in pods that are low to the ground.

## Compressor Types

The two principal types of compressors currently being used in gas turbine aircraft engines are centrifugal flow and axial flow. The centrifugal-flow compressor achieves its purpose by picking up the entering air and accelerating it outwardly by centrifugal action. The axial-flow compressor compresses air while the air continues in its original direction of flow, thus avoiding the energy loss caused by turns. The components of each of these two types of compressor have their individual functions in the compression of air for the combustion section. A stage in a compressor is considered to be a rise in pressure.

### *Centrifugal-Flow Compressors*

The centrifugal-flow compressor consists of an impeller (rotor), a diffuser (stator), and a compressor manifold. *[Figure 1-46]* Centrifugal compressors have a high pressure rise per stage that can be around 8:1. Generally centrifugal



**Figure 1-44.** Typical turbofan inlet.

compressors are limited to two stages due to efficiency concerns. The two main functional elements are the impeller and the diffuser. Although the diffuser is a separate unit and is placed inside and bolted to the manifold, the entire assembly (diffuser and manifold) is often referred to as the diffuser. For clarification during compressor familiarization, the units are treated individually. The impeller is usually made from forged aluminum alloy, heat treated, machined, and smoothed for minimum flow restriction and turbulence.

In most types, the impeller is fabricated from a single forging. This type impeller is shown in *Figure 1-46*. The impeller, whose function is to pick up and accelerate the air outwardly to the diffuser, may be either of two types—single entry or double entry. The principal differences between the two types of impellers are size and ducting arrangement. The double-entry type has a smaller diameter but is usually operated at a higher rotational speed to assure sufficient airflow. The single-entry impeller, shown in *Figure 1-47*, permits convenient ducting directly to the impeller eye (inducer vanes) as opposed to the more complicated ducting necessary to reach the rear side of the double-entry type. Although slightly more efficient in receiving air, the single-entry impeller must be large in diameter to deliver the same quantity of air as the double-entry type. This, of course, increases the overall diameter of the engine.

Included in the ducting for double-entry compressor engines is the plenum chamber. This chamber is necessary for a double-entry compressor because the air must enter the engine at almost right angles to the engine axis. Therefore, in order to give a positive flow, the air must surround the engine compressor at a positive pressure before entering

the compressor. Included in some installations as necessary parts of the plenum chamber are the auxiliary air-intake doors (blow-in doors). These blow-in doors admit air to the engine compartment during ground operation, when air requirements for the engine are in excess of the airflow through the inlet ducts. The doors are held closed by spring action when the engine is not operating. During operation, however, the doors open automatically whenever engine compartment pressure drops below atmospheric pressure. During takeoff and flight, ram air pressure in the engine compartment aids the springs in holding the doors closed.

The diffuser is an annular chamber provided with a number of vanes forming a series of divergent passages into the manifold. The diffuser vanes direct the flow of air from the impeller to the manifold at an angle designed to retain the maximum amount of energy imparted by the impeller. They also deliver the air to the manifold at a velocity and pressure satisfactory for use in the combustion chambers. Refer to *Figure 1-46A* and note the arrow indicating the path of airflow through the diffuser, then through the manifold.

The compressor manifold shown in *Figure 1-46A* diverts the flow of air from the diffuser, which is an integral part of the manifold, into the combustion chambers. The manifold has one outlet port for each chamber so that the air is evenly divided. A compressor outlet elbow is bolted to each of the outlet ports. These air outlets are constructed in the form of ducts and are known by a variety of names, such as air outlet ducts, outlet elbows, or combustion chamber inlet ducts. Regardless of the terminology used, these outlet ducts perform a very important part of the diffusion process; that is, they change the radial direction of the airflow to an axial direction, in which the diffusion process is completed after the turn. To help the elbows perform this function in an efficient manner, turning vanes (cascade vanes) are sometimes fitted inside the elbows. These vanes reduce air pressure losses by



**Figure 1-45.** Typical turboprop accessory case.

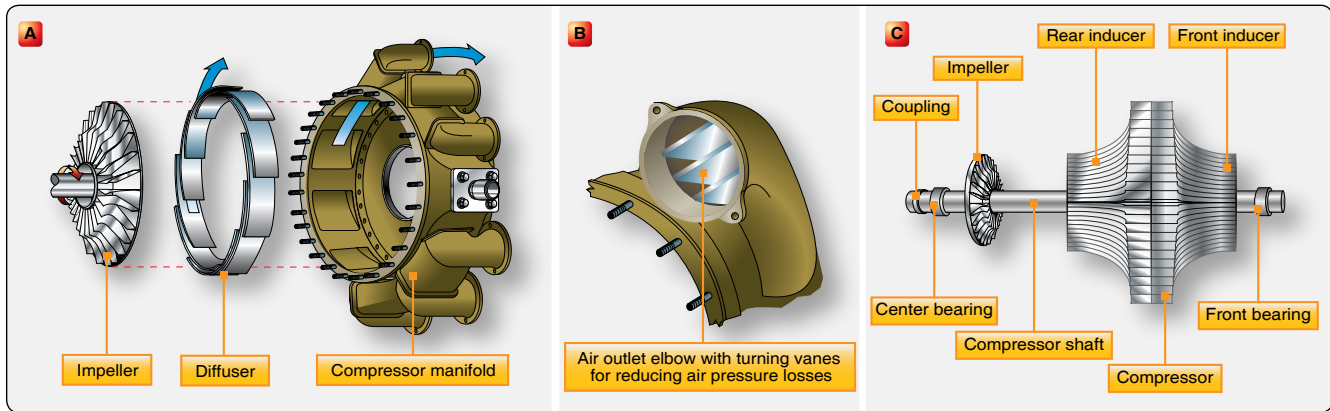

**Figure 1-46.** (A) Components of a centrifugal-flow compressor; (B) Air outlet elbow with turning vanes for reducing air pressure losses; (C) Components of a double-entry centrifugal-flow compressor.



**Figure 1-47.** Single-entry impeller.

presenting a smooth, turning surface. [Figure 1-46B]

### Axial-Flow Compressor

The axial flow compressor is a combination of an engine compressor and high-pressure turbine that drives it using a connecting drive shaft. In a single-spool engine, the high-pressure turbine drives the entire compressor. In a dual-spool engine, the compressor and high-pressure turbine are both split into two segments. Each compressor segment is driven by its corresponding turbine using two separate drive shafts, with one inside the other. The first stage turbine drives the N2 compressor.

The axial-flow compressor has two main elements: a rotor and a stator. The rotor has blades fixed on a spindle. These blades impel air rearward in the same manner as a propeller because of their angle and airfoil contour. The rotor, turning at high speed, takes in air at the compressor inlet and impels it through a series of stages. From inlet to exit, the air flows along an axial path and is compressed at a ratio of approximately 1.25:1 per stage. The action of the

rotor increases the compression of the air at each stage and accelerates it rearward through several stages. With this increased velocity, energy is transferred from the compressor to the air in the form of velocity energy. The stator blades act as diffusers at each stage, partially converting high velocity to pressure. Each consecutive pair of rotor and stator blades constitutes a pressure stage. The number of rows of blades (stages) is determined by the amount of air and total pressure rise required. Compressor pressure ratio increases with the number of compression stages. Most engines utilize up to 16 stages and more.

The stator has rows of vanes, which are in turn attached inside an enclosing case. The stator vanes, which are stationary, project radially toward the rotor axis and fit closely on either side of each stage of the rotor blades. In some cases, the compressor case, into which the stator vanes are fitted, is horizontally divided into halves. Either the upper or lower half may be removed for inspection or maintenance of rotor and stator blades.

The function of the stator vanes is to receive air from the air inlet duct or from each preceding stage and increase the pressure of the air and deliver it to the next stage at the correct velocity and pressure. They also control the direction of air to each rotor stage to obtain the maximum possible compressor blade efficiency. Shown in *Figure 1-48* are the rotor and stator elements of a typical axial-flow compressor. The first stage rotor blades can be preceded by an inlet guide vane assembly that can be fixed or variable.

The guide vanes direct the airflow into the first stage rotor blades at the proper angle and impart a swirling motion to the air entering the compressor. This preswirl, in the direction of engine rotation, improves the aerodynamic characteristics of the compressor by reducing drag on the first stage rotor blades. The inlet guide vanes are curved steel vanes usually welded to steel inner and outer shrouds.

At the discharge end of the compressor, the stator vanes are constructed to straighten the airflow to eliminate turbulence. These vanes are called straightening vanes or the outlet vane assembly. The casings of axial-flow compressors not only support the stator vanes and provide the outer wall of the axial path the air follows, but they also provide the means for extracting compressor air for various purposes. The stator vanes are usually made of steel with corrosion- and erosion-resistant qualities. Quite frequently, they are shrouded (enclosed) by a band of suitable material to simplify the fastening problem. The vanes are welded into the shrouds, and the outer shroud is secured to the compressor housing inner wall by radial retaining screws.

The rotor blades are usually made of stainless steel with the latter stages being made of titanium. The design of blade attachment to the rotor disc rims varies, but they are commonly fitted into discs by either bulb-type or fir-tree methods. [Figure 1-49] The blades are then locked into place by differing methods. Compressor blade tips are reduced

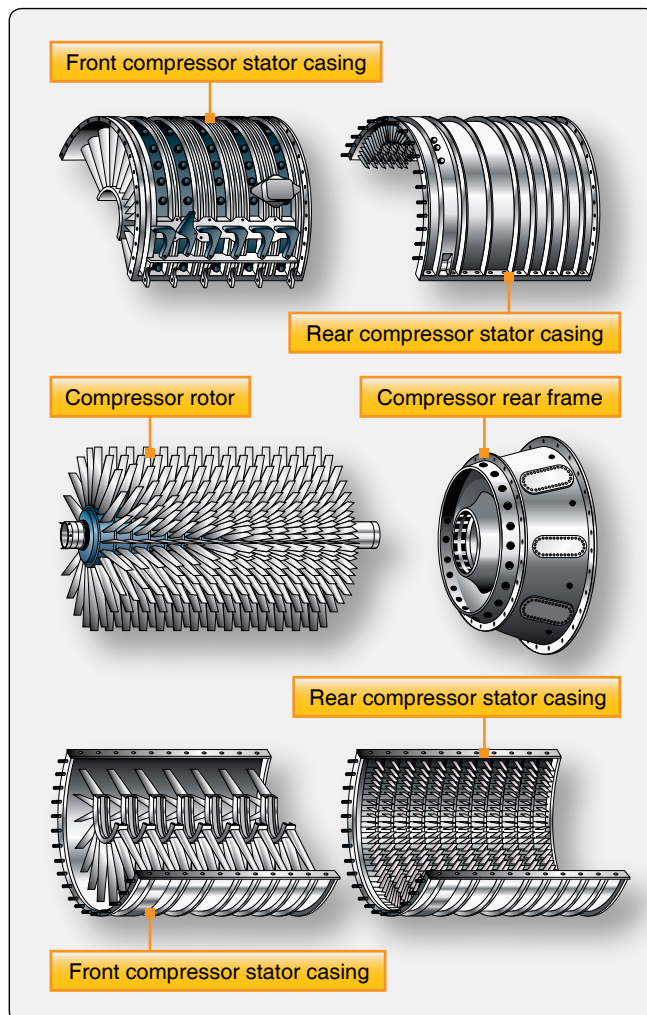

**Figure 1-48.** Rotor and stator elements of a typical axial-flow compressor.

in thickness by cutouts, referred to as blade profiles. These profiles prevent serious damage to the blade or housing should the blades contact the compressor housing. This condition can occur if rotor blades become excessively loose or if rotor support is reduced by a malfunctioning bearing. Even though blade profiles greatly reduce such possibilities, occasionally a blade may break under stress of rubbing and cause considerable damage to compressor blades and stator vane assemblies. The blades vary in length from entry to discharge because the annular working space (drum to casing) is reduced progressively toward the rear by the decrease in the casing diameter. [Figure 1-50] This feature provides for a fairly constant velocity through the compressor, which helps to keep the flow of air constant.

The rotor features either drum-type or disc-type construction. The drum-type rotor consists of rings that are flanged to fit one against the other, wherein the entire assembly can then be held together by through bolts. This type of construction is satisfactory for low-speed compressors where centrifugal stresses are low. The disc-type rotor consists of a series of discs machined from aluminum forgings, shrunk over a steel shaft, with rotor blades dovetailed into the disc rims. Another method of rotor construction is to machine the discs and shaft from a single aluminum forging, and then to bolt steel stub shafts on the front and rear of the assembly to provide bearing support surfaces and splines for joining the turbine shaft. The drum-type and disc-type rotors are illustrated in Figures 1-50 and 1-51, respectively.

The combination of the compressor stages and turbine stages on a common shaft is an engine referred to as an engine spool. The common shaft is provided by joining the turbine and compressor shafts by a suitable method. The engine's spool is supported by bearings, which are seated in suitable bearing housings.

As mentioned earlier, there are two configurations of the axial compressor currently in use: the single rotor/spool and the dual rotor/spool, sometimes referred to as solid spool and split spool (two spool, dual spool).

One version of the solid-spool (one spool) compressor uses variable inlet guide vanes. Also, the first few rows of stator vanes are variable. The main difference between variable inlet guide vane (VIGV) and a variable stator vane (VSV) is their position with regard to the rotor blades. VIGV are in front of the rotor blades, and VSV are behind the rotor blades. The angles of the inlet guide vanes and the first several stages of the stator vanes are can be variable. During operation, air enters the front of the engine and is directed into the compressor at the proper angle by the variable inlet guide and directed by the VSV. The air is compressed and forced into the combustion

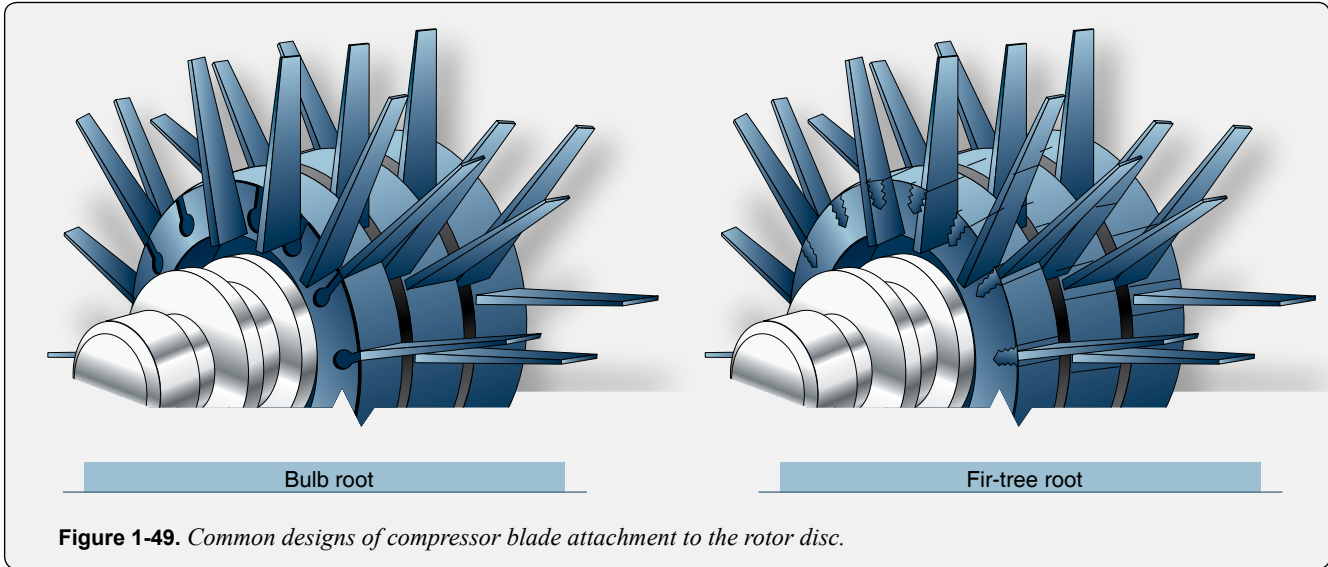

**Figure 1-49.** Common designs of compressor blade attachment to the rotor disc.

section. A fuel nozzle that extends into each combustion liner atomizes the fuel for combustion. These variables are controlled in direct relation to the amount of power the engine is required to produce by the power lever position.

Most turbofan engines are of the split-spool compressor type. Most large turbofan engines use a large fan with a few stages of compression called the low-pressure spool. These turbofans incorporate two compressors with their respective turbines and interconnecting shafts, which form two physically independent

rotor systems. Many dual rotor systems have rotors turning in opposite directions and with no mechanical connection to each other. The second spool, referred to as the high-pressure spool and is the compressor for the gas generator and core of the engine, supplies air to the combustion section of the engine.

The advantages and disadvantages of both types of compressors are included in the following list. Even though each type has advantages and disadvantages, each has its use by type and size of engine.

The centrifugal-flow compressor's advantages are:

- High pressure rise per stage,
- Efficiency over wide rotational speed range,
- Simplicity of manufacture and low cost,

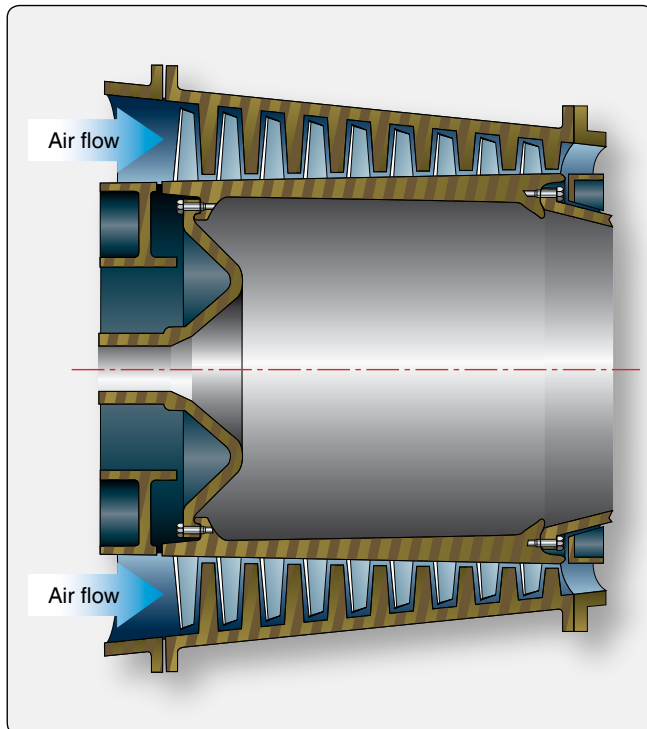

**Figure 1-50.** Drum-type compressor rotor.

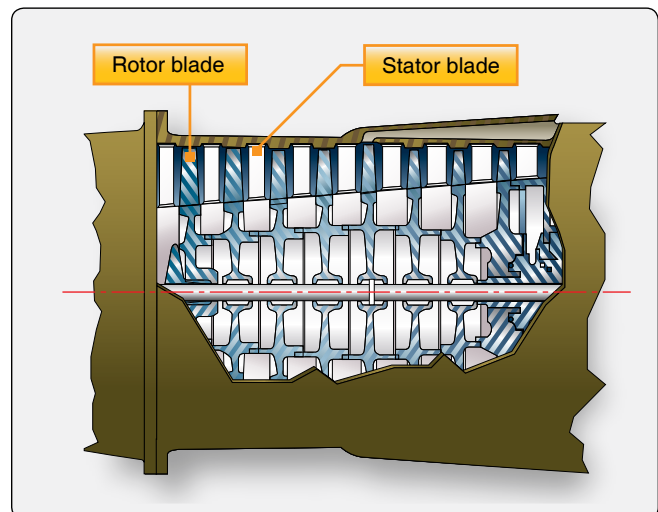

**Figure 1-51.** Disc-type compressor rotor.

- Low weight, and
- Low starting power requirements.

The centrifugal-flow compressor's disadvantages are:

- Its large frontal area for a given airflow and
- Losses in turns between stages.

The axial-flow compressor's advantages are:

- High peak efficiencies;
- Small frontal area for given airflow;
- Straight-through flow, allowing high ram efficiency; and
- Increased pressure rise by increasing number of stages, with negligible losses.

The axial-flow compressor's disadvantages are:

- Good efficiencies over only narrow rotational speed range,
- Difficulty of manufacture and high cost,
- Relatively high weight, and
- High starting power requirements (partially overcome by split compressors).

## Diffuser

The diffuser is the divergent section of the engine after the compressor and before the combustion section. It has the all-important function of reducing high-velocity compressor discharge air to increased pressure at a slower velocity. This prepares the air for entry into the flame burning area of the combustion section at a lower velocity so that the flame of combustion can burn continuously. If the air passed through the flame area at a high velocity, it could extinguish the flame.

## Combustion Section

The combustion section houses the combustion process, which raises the temperature of the air passing through the engine. This process releases energy contained in the air-fuel mixture. The major part of this energy is required at the turbine or turbine stages to drive the compressor. About  $\frac{2}{3}$  of the energy is used to drive the gas generator compressor. The remaining energy passes through the remaining turbine stages that absorb more of the energy to drive the fan, output shaft, or propeller. Only the pure turbojet allows the air to create all the thrust or propulsion by exiting the rear of the engine in the form of a high-velocity jet. These other engine types have some jet velocity out the rear of the engine but most of the thrust or power is generated by the additional turbine stages driving a large fan, propeller, or helicopter rotor blades.

The primary function of the combustion section is, of course, to burn the air-fuel mixture, thereby adding heat energy to the air. To do this efficiently, the combustion chamber must:

- Provide the means for proper mixing of the fuel and air to assure good combustion,
- Burn this mixture efficiently,
- Cool the hot combustion products to a temperature that the turbine inlet guide vanes/blades can withstand under operating conditions, and
- Deliver the hot gases to the turbine section.

The location of the combustion section is directly between the compressor and the turbine sections. The combustion chambers are always arranged coaxially with the compressor and turbine regardless of type, since the chambers must be in a through-flow position to function efficiently. All combustion chambers contain the same basic elements:

1. Casing.
2. Perforated inner liner.
3. Fuel injection system.
4. Some means for initial ignition.
5. Fuel drainage system to drain off unburned fuel after engine shutdown.

There are currently four basic types of combustion chambers, variations within type being in detail only. These types are:

1. Can-type.
2. Can-annular type.
3. Annular type.
4. Reverse-flow type.

The can-type combustion chamber is typical of the type used on turboshaft and APUs. [Figure 1-52] Each of the can-type combustion chambers consists of an outer case or housing, within which there is a perforated stainless steel (highly heat resistant) combustion chamber liner or inner liner. [Figure 1-53] The outer case is removed to facilitate liner replacement.

Older engines with several combustion cans had each can with interconnector (flame propagation) tube, which was a necessary part of the can-type combustion chambers. Since each can is a separate burner operating independently of the other cans, there must be some way to spread combustion during the initial starting operation. This is accomplished by interconnecting all the chambers. As the flame is started by the spark igniter plugs in two of the lower chambers, it passes through the tubes and ignites the combustible mixture in the adjacent chamber and continues until all the chambers

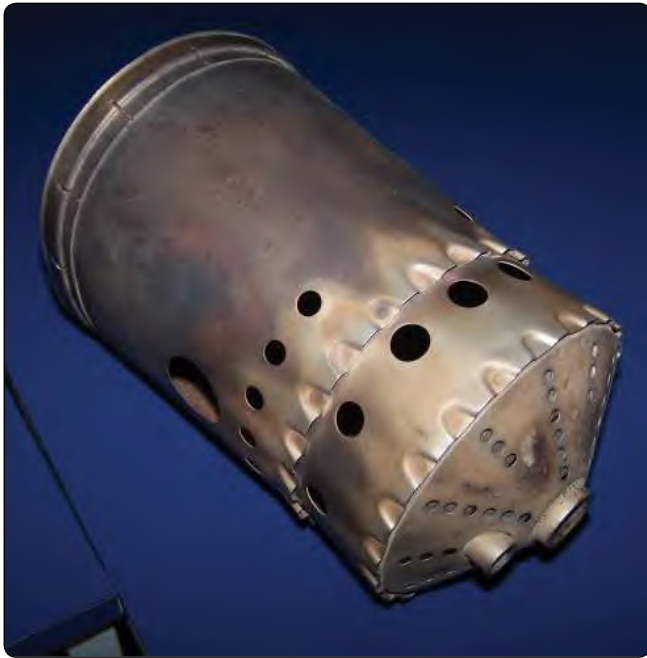

Figure 1-52. Can-type combustion chamber.



Figure 1-53. Inside view of a combustion chamber liner.

are burning.

The flame tubes vary in construction details from one engine to another, although the basic components are almost identical. [Figure 1-54] The spark igniters previously mentioned are normally two in number and are located in two of the can-type combustion chambers.

Another very important requirement in the construction of combustion chambers is providing the means for draining unburned fuel. This drainage prevents gum deposits in the fuel manifold, nozzles, and combustion chambers. These deposits

are caused by the residue left when the fuel evaporates. Probably most important is the danger of afterfire if the fuel is allowed to accumulate after shutdown. If the fuel is not drained, a great possibility exists that, at the next starting attempt, the excess fuel in the combustion chamber will ignite and exhaust gas temperature will exceed safe operating limits.

The liners of the can-type combustors have perforations of various sizes and shapes, each hole having a specific purpose and effect on flame propagation within the liner. [Figure 1-52] The air entering the combustion chamber is divided by the proper holes, louvers, and slots into two main streams—primary and secondary air. The primary or combustion air is directed inside the liner at the front end, where it mixes with the fuel and is burned. Secondary or cooling air passes between the outer casing and the liner and joins the combustion gases through larger holes toward the rear of the liner, cooling the combustion gases from about 3,500 °F to near 1,500 °F. To aid in atomization of the fuel, holes are provided around the fuel nozzle in the dome or inlet end of the can-type combustor liner. Louvers are also provided along the axial length of the liners to direct a cooling layer of air along the inside wall of the liner. This layer of air also tends to control the flame pattern by keeping it centered in the liner, thereby preventing burning of the liner walls. Figure 1-55 illustrates the annular combustion chamber liner.

Some provision is always made in the combustion chamber case for installation of a fuel nozzle. The fuel nozzle delivers the fuel into the liner in a finely atomized spray. The more the spray is atomized, the more rapid and efficient the burning process is.

Two types of fuel nozzle currently being used in the various types of combustion chambers are the simplex nozzle and the duplex nozzle. The construction features of these nozzles are covered in greater detail in Chapter 2, Engine Fuel & Fuel Metering Systems.

The spark igniter plugs of the annular combustion chamber are the same basic type used in the can-type combustion chambers, although construction details may vary. There are usually two igniters mounted on the boss provided on each of the chamber housings. The igniters must be long enough to protrude from the housing into the combustion chamber.

The burners are interconnected by projecting flame tubes which facilitate the engine-starting process as mentioned previously in the can-type combustion chamber familiarization. The flame tubes function identically to those previously discussed, differing only in construction details.

The can-annular combustion chamber is not used in modern

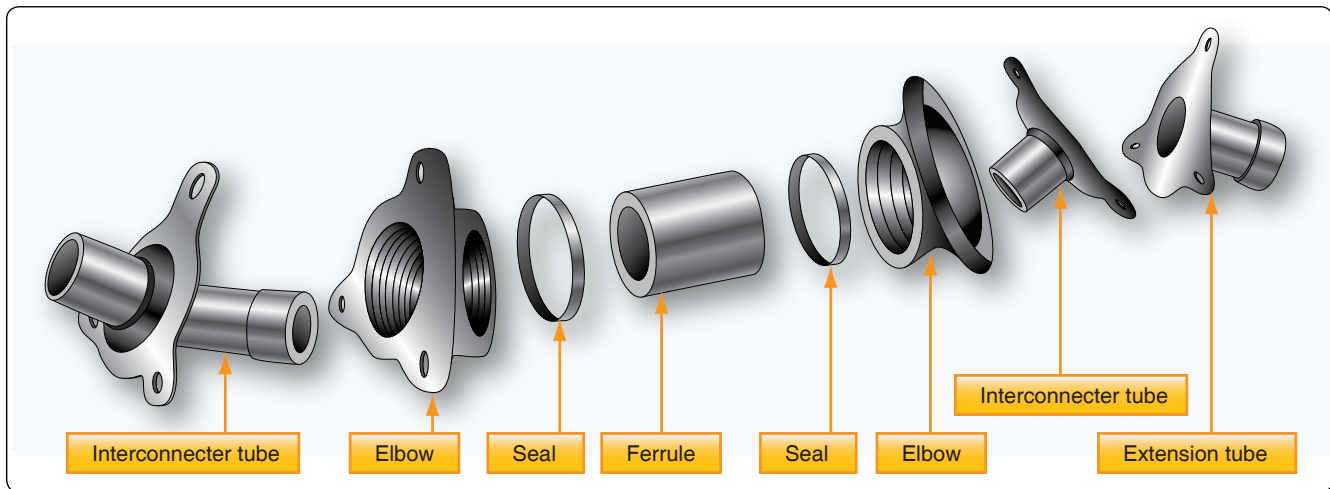

**Figure 1-54.** Interconnecting flame tubes for can-type combustion chambers.

engines. The forward face of each chamber presents six apertures, which align with the six fuel nozzles of the corresponding fuel nozzle cluster. [Figure 1-56] These nozzles are the dual-orifice (duplex) type requiring the use of a flow-divider (pressurizing valve), as mentioned in the can-type combustion chamber discussion. Around each nozzle are preswirl vanes for imparting a swirling motion to the fuel spray, which results in better atomization of the fuel, better burning, and efficiency. The swirl vanes function to provide two effects imperative to proper flame propagation:

1. High flame speed—better mixing of air and fuel, ensuring spontaneous burning.
2. Low air velocity axially—swirling eliminates overly rapid flame movement axially.

The swirl vanes greatly aid flame propagation, since a high degree of turbulence in the early combustion and cooling stages is desirable. The vigorous mechanical mixing of the fuel vapor with the primary air is necessary, since mixing by diffusion alone is too slow. This same mechanical mixing is also established by other means, such as placing coarse

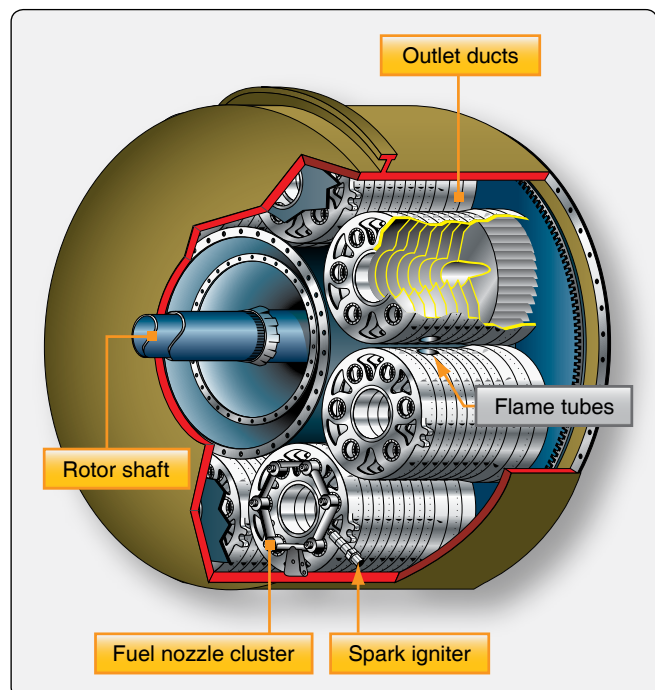

**Figure 1-55.** Annular combustion chamber liner.

screens in the diffuser outlet, as is the case in most axial-flow engines.

The can-annular combustion chambers also must have the required fuel drain valves located in two or more of the bottom chambers, assuring proper drainage and elimination of residual fuel burning at the next start.

The flow of air through the holes and louvers of the can-annular chambers, is almost identical with the flow through other types of burners. [Figure 1-56] Special baffling is used to swirl the combustion airflow and to give it turbulence. Figure 1-57 shows the flow of combustion air, metal cooling air, and the diluent or gas cooling air. The air flow direction



**Figure 1-56.** Can-annular combustion chamber components and arrangement.

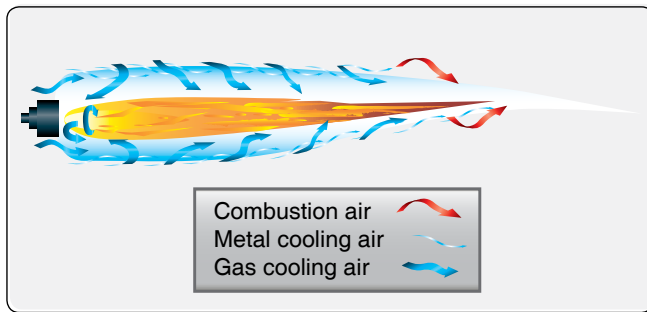

**Figure 1-57.** Airflow through a can-annular combustion chamber.

is indicated by the arrows.

The basic components of an annular combustion chamber are a housing and a liner, as in the can type. The liner consists of an undivided circular shroud extending all the way around the outside of the turbine shaft housing. The chamber is constructed of heat-resistant materials, which are sometimes coated with thermal barrier materials, such as ceramic materials. The annular combustion chamber is illustrated in *Figure 1-58*. Modern turbine engines usually have an annular combustion chamber. As can be seen in *Figure 1-59*, the annular combustion chamber also uses louvers and holes to prevent the flame from contacting the side of the combustion chamber.

A reverse-flow combustor is a type of combustor in which the air from the compressor enters the combustor outer case and reverses its direction as it flows into the inner liner. It again reverses its direction before it flows through the turbine. Reverse-flow combustors are used where engine length is critical.

### Turbine Section

The turbine transforms a portion of the kinetic (velocity) energy of the exhaust gases into mechanical energy to drive the gas generator compressor and accessories. The sole purpose of the gas generator turbine is to absorb approximately 60 to 70 percent of the total pressure energy from the exhaust gases. The exact amount of energy absorption at the turbine is determined by the load the turbine is driving (i.e., compressor size and type, number of accessories, and the load applied by the other turbine stages). These turbine stages can be used to drive a low-pressure compressor (fan), propeller, and shaft. The turbine section of a gas turbine engine is located aft, or downstream, of the combustion chamber. Specifically, it is directly behind the combustion chamber outlet.

The turbine assembly consists of two basic elements: turbine inlet guide vanes and turbine disc. [*Figures 1-60 and 1-61*] The stator element is known by a variety of names, of which turbine inlet nozzle vanes, turbine inlet guide vanes, and nozzle diaphragm are three of the most commonly used.



**Figure 1-58.** Annular combustion chamber with ceramic coating.

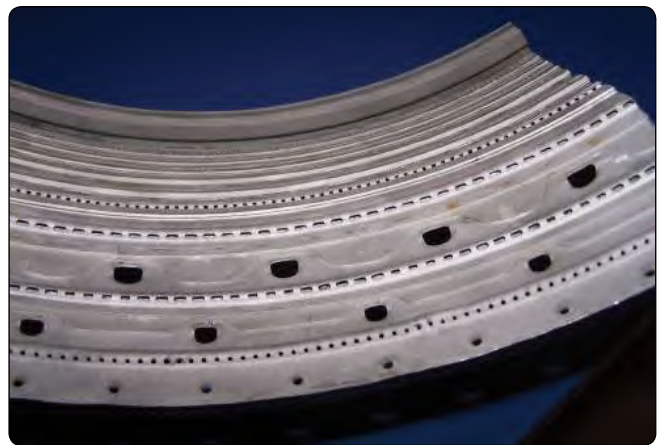

**Figure 1-59.** Combustion chamber louvers and holes.



**Figure 1-60.** Turbine inlet guide vanes.

The turbine inlet nozzle vanes are located directly aft of the combustion chambers and immediately forward of the turbine wheel. This is the highest or hottest temperature that comes in contact with metal components in the engine. The turbine inlet temperature must be controlled, or damage will occur to the turbine inlet vanes.

After the combustion chamber has introduced the heat energy into the mass airflow and delivered it evenly to the turbine



**Figure 1-61.** Turbine disc.

inlet nozzles, the nozzles must prepare the mass air flow to drive the turbine rotor. The stationary vanes of the turbine inlet nozzles are contoured and set at such an angle that they form a number of small nozzles discharging gas at extremely high speed; thus, the nozzle converts a varying portion of the heat and pressure energy to velocity energy that can then be converted to mechanical energy through the turbine blades.

There are three types of turbine blades: the impulse turbine blade, reaction turbine blade, and the reaction-impulse turbine blade. The impulse turbine blade is also referred to as a bucket. This is because as the stream of air strikes the center of the blade it changes the direction of the energy as it causes the blades to rotate the disc and rotor shaft. The turbine nozzle guide vanes can usually be adjusted during engine overhaul and assembly in order to increase the efficiency of the air stream striking the blades or buckets of the turbine. [Figure 1-62]

Reaction turbine blades cause the disc to rotate by the aerodynamic action of the airstream directed to flow past the blade at a particular angle in order to develop the most efficient power from the turbine engine. [Figure 1-62]

The reaction-impulse turbine blade combines the action of both the impulse and reaction blades designs. The blade has more of the bucket shape of the impulse blade at the blade root and it also has more of an airfoil shape of the reaction blade on the second half of the blade toward the outer end of the blade.

The second purpose of the turbine inlet nozzle is to deflect the gases to a specific angle in the direction of turbine wheel rotation. Since the gas flow from the nozzle must enter the turbine blade passageway while it is still rotating, it is essential to aim the gas in the general direction of turbine rotation.

The turbine inlet nozzle assembly consists of an inner

shroud and an outer shroud between which the nozzle vanes are fixed. The number and size of inlet vanes employed vary with different types and sizes of engines. *Figure 1-63* illustrates typical turbine inlet nozzles featuring loose and welded vanes. The vanes of the turbine inlet nozzle may be assembled between the outer and inner shrouds or rings in a variety of ways. Although the actual elements may vary slightly in configuration and construction features, there is one characteristic peculiar to all turbine inlet nozzles: the nozzle vanes must be constructed to allow thermal expansion. Otherwise, there would be severe distortion or warping of the metal components because of rapid temperature changes.

The thermal expansion of turbine nozzles is accomplished by one of several methods. One method necessitates loose assembly of the supporting inner and outer vane shrouds. [Figure 1-63A]

Each vane fits into a contoured slot in the shrouds, which conforms to the airfoil shape of the vane. These slots are slightly larger than the vanes to give a loose fit. For further support, the inner and outer shrouds are encased by inner and outer support rings, which provide increased strength and rigidity. These support rings also facilitate removal of the nozzle vanes as a unit. Without the rings, the vanes could fall out as the shrouds were removed.

Another method of thermal expansion construction is to fit the vanes into inner and outer shrouds; however, in this method the vanes are welded or riveted into position. [Figure 1-63B] Some means must be provided to allow thermal expansion; therefore, either the inner or the outer shroud ring is cut into segments. The saw cuts separating the segments allow sufficient expansion to prevent stress and warping of the vanes.

The rotor element of the turbine section consists essentially of a shaft and a wheel. [Figure 1-64] The turbine wheel is a dynamically balanced unit consisting of blades attached to a rotating disc. The disc, in turn, is attached to the main power-transmitting shaft of the engine. The exhaust gases leaving the turbine inlet nozzle vanes act on the blades of the turbine wheel, causing the assembly to rotate at a very high rate of speed. The high rotational speed imposes severe centrifugal loads on the turbine wheel, and at the same time the elevated temperatures result in a lowering of the strength of the material. Consequently, the engine speed and temperature must be controlled to keep turbine operation within safe limits.

The turbine disc is referred to as such without blades. When the turbine blades are installed, the disc then becomes the turbine wheel. The disc acts as an anchoring component for the turbine blades. Since the disc is bolted or welded to the

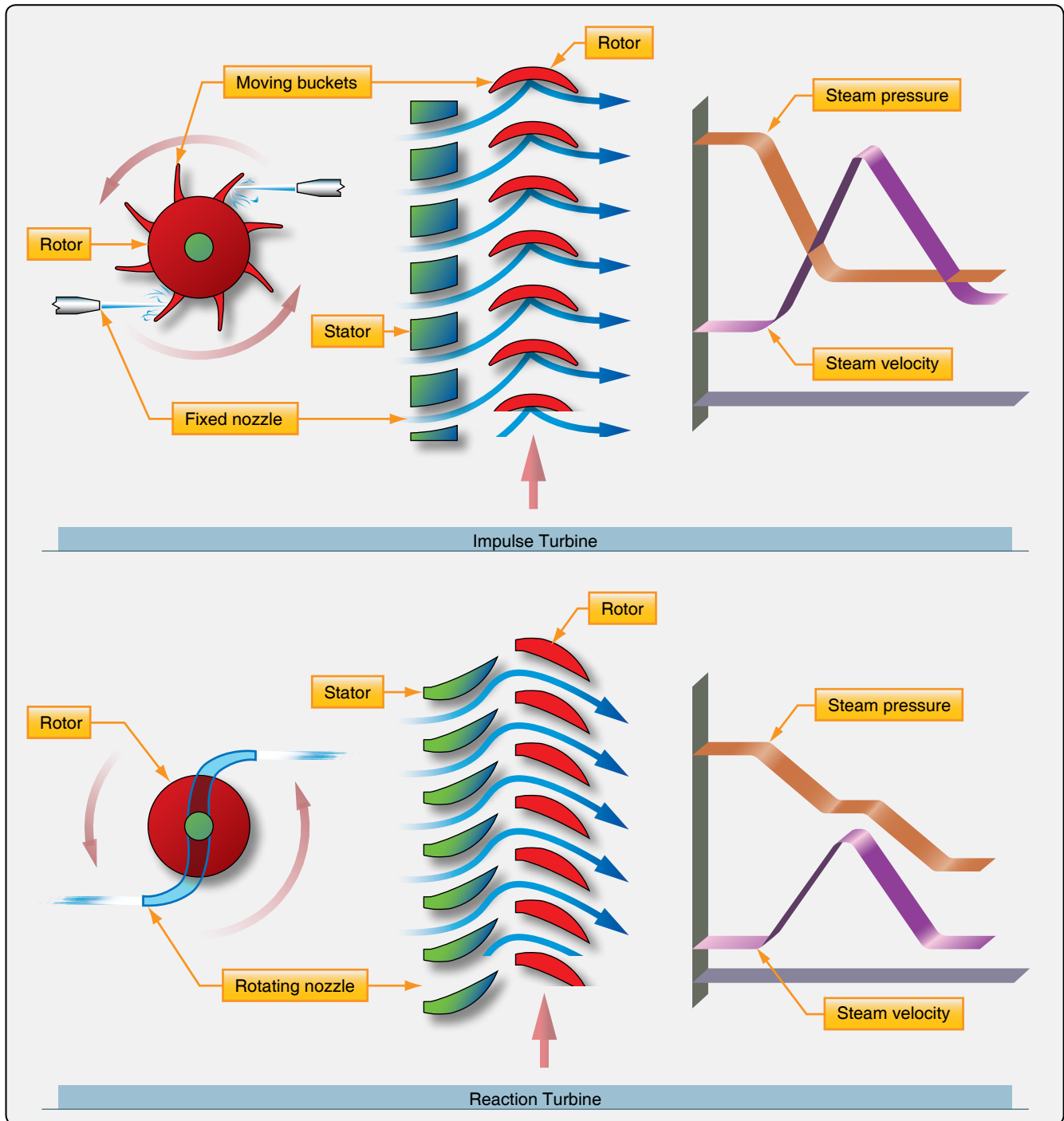

Figure 1-62. Impulse and reaction turbine blades.

shaft, the blades can transmit to the rotor shaft the energy they extract from the exhaust gases.

The disc rim is exposed to the hot gases passing through the blades and absorbs considerable heat from these gases. In addition, the rim also absorbs heat from the turbine blades by conduction. Hence, disc rim temperatures are normally high and well above the temperatures of the more remote inner portion of the disc. As a result of these temperature gradients, thermal stresses are added to the rotational stresses.

Additionally, turbine blades are generally more susceptible to operating damage than compressor blades due to the exposure of high temperatures. There are various methods to relieve, at least partially, the aforementioned stresses. One such method is to bleed cooling air back onto the face of the disc.

Another method of relieving the thermal stresses of the disc is incidental to blade installation. A series of grooves or notches, conforming to the blade root design, are broached in the rim of the disc. These grooves allow attachment of the

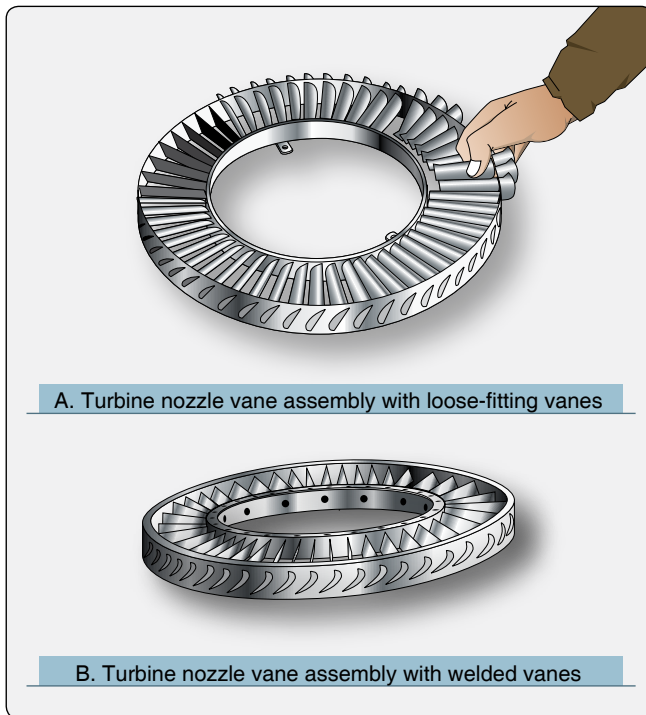

**Figure 1-63.** Typical turbine nozzle vane assemblies.

turbine blades to the disc; at the same time, space is provided by the notches for thermal expansion of the disc. Sufficient clearance exists between the blade root and the notch to permit movement of the turbine blade when the disc is cold. During engine operation, expansion of the disc decreases the clearance. This causes the blade root to fit tightly in the disc rim.

The turbine shaft is usually fabricated from alloy steel. [Figure 1-64] It must be capable of absorbing the high torque loads that are exerted on it.

The methods of connecting the shaft to the turbine disc vary. In one method, the shaft is welded to the disc, which has a butt or protrusion provided for the joint. Another method is by bolting. This method requires that the shaft have a hub that fits a machined surface on the disc face. Then, the bolts are inserted through holes in the shaft hub and anchored in tapped holes in the disc. Of the two connection methods, bolting is more common.

The turbine shaft must have some means for attachment to the compressor rotor hub. This is usually accomplished by a spline cut on the forward end of the shaft. The spline fits into a coupling device between the compressor and turbine shafts. If a coupling is not used, the splined end of the turbine shaft may fit into a splined recess in the compressor rotor hub. This splined coupling arrangement is used almost exclusively with centrifugal compressor engines, while axial compressor engines may use either of these described methods.

There are various ways of attaching turbine blades, some similar to compressor blade attachment. The most satisfactory method utilizes the fir-tree design. [Figure 1-65]

The blades are retained in their respective grooves by a variety of methods, the more common of which are peening, welding, lock tabs, and riveting. Figure 1-66 shows a typical turbine wheel using rivets for blade retention.

The peening method of blade retention is used frequently in various ways. One of the most common applications of peening requires a small notch to be ground in the edge of the blade fir-tree root prior to the blade installation. After the blade is inserted into the disc, the notch is filled by the disc metal, which is “flowed” into it by a small punch-mark made in the disc adjacent to the notch. The tool used for this job is similar to a center punch.

Another method of blade retention is to construct the root of the blade so that it contains all the elements necessary for its retention. This method uses the blade root as a stop made on one end of the root so that the blade can be inserted and removed in one direction only, while on the opposite end is a tang. This tang is bent to secure the blade in the disc.

Turbine blades may be either forged or cast, depending on the composition of the alloys. Most blades are precision cast and finish ground to the desired shape. Many turbine blades are cast as a single crystal, which gives the blades better strength and heat properties. Heat barrier coating, such as ceramic coating, and air flow cooling help keep the turbine blades and inlet nozzles cooler. This allows the exhaust temperature to be raised, increasing the efficiency of the engine. Figure 1-67



**Figure 1-64.** Rotor elements of the turbine assembly.

shows a turbine blade with air holes for cooling purposes.

Most turbines are open at the outer perimeter of the blades; however, a second type called the shrouded turbine is sometimes used. The shrouded turbine blades, in effect, form a band around the outer perimeter of the turbine wheel. This improves efficiency and vibration characteristics and permits lighter stage weights. On the other hand, it limits turbine speed and requires more blades. [Figure 1-68]

In turbine rotor construction, it occasionally becomes necessary to utilize turbines of more than one stage. A single turbine wheel often cannot absorb enough power from the exhaust gases to drive the components dependent on the turbine for rotative power; thus, it is necessary to add additional turbine stages.

A turbine stage consists of a row of stationary vanes or nozzles, followed by a row of rotating blades. In some models of turboprop engine, as many as five turbine stages have been utilized successfully. It should be remembered that, regardless of the number of wheels necessary for driving engine components, there is always a turbine nozzle preceding each wheel.

As was brought out in the preceding discussion of turbine stages, the occasional use of more than one turbine wheel is warranted in cases of heavy rotational loads. It should also be pointed out that the same loads that necessitate multistage turbines often make it advantageous to incorporate multiple compressor rotors.

In the single-stage rotor turbine, the power is developed by one turbine rotor, and all engine-driven parts are driven by

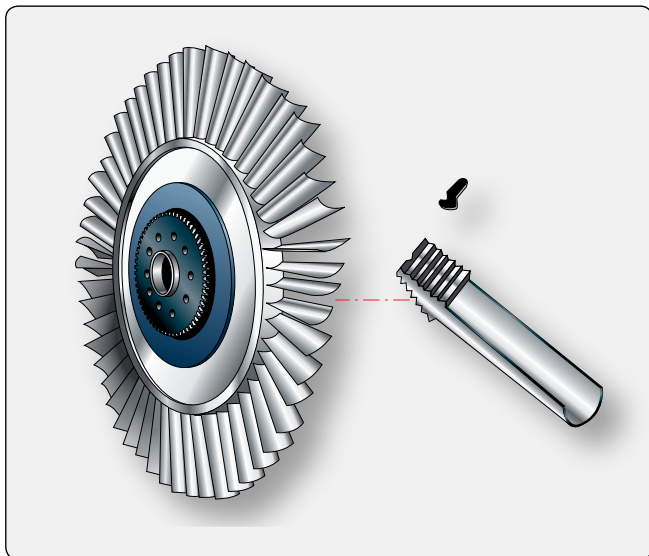

**Figure 1-65.** Turbine blade with fir-tree design and lock-tab method of blade retention.

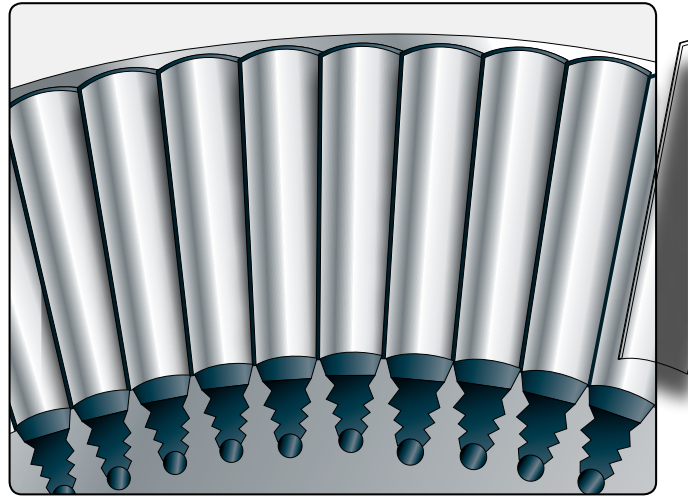
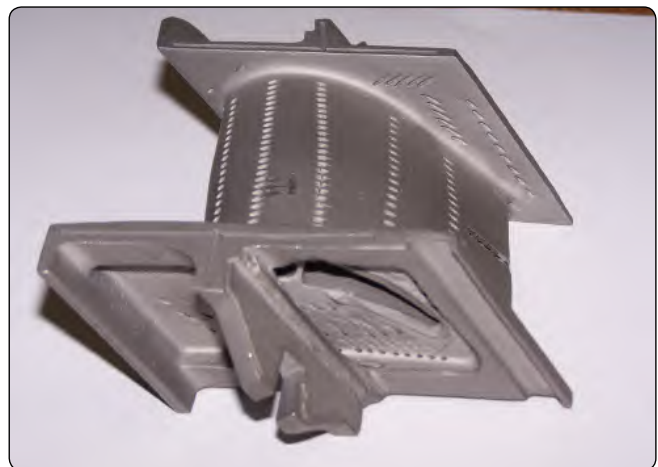

**Figure 1-66.** Rivet method of turbine blade retention.

this single wheel. [Figure 1-69] This arrangement is used on engines where the need for low weight and compactness predominates. This is the simplest version of the pure turbojet engine.

A multistage turbine is shown in Figure 1-70. In multiple spool engines, each spool has its own set of turbine stages. Each set of turbine stages turns the compressor attached to it. Most turbofan engines have two spools: low pressure (fan shaft a few stages of compression and the turbine to drive it) and high pressure (high pressure compressor shaft and high pressure turbine). [Figure 1-71]

The remaining element to be discussed concerning turbine familiarization is the turbine casing or housing. The turbine casing encloses the turbine wheel and the nozzle vane assembly, and at the same time gives either direct or indirect support to the stator elements of the turbine section. It always has flanges provided front and rear for bolting the assembly to the combustion chamber housing and the exhaust cone assembly, respectively. A turbine casing is illustrated in



**Figure 1-67.** Turbine blade with cooling holes.

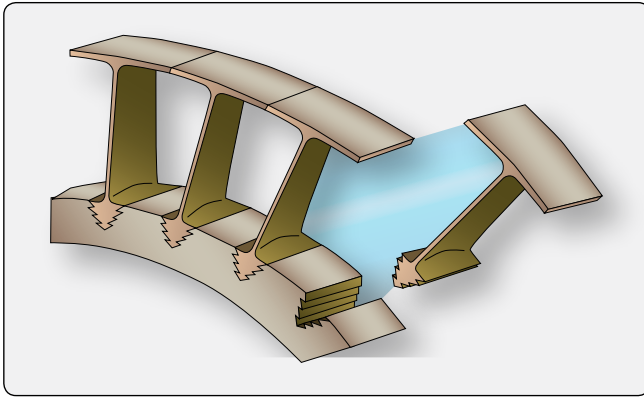

Figure 1-68. Shrouded turbine blades.

Figure 1-72.

### Exhaust Section

The exhaust section of the gas turbine engine consists of several components. Although the components have individual purposes, they also have one common function: they must direct the flow of hot gases rearward in such a manner as to prevent turbulence and, at the same time, impart a high final or exit velocity to the gases. In performing the various functions, each of the components affects the flow of gases in different ways. The exhaust section is located directly behind the turbine section and ends when the gases are ejected at the rear in the form of high-velocity exhaust gases. The components of the exhaust section include the exhaust cone, tailpipe (if required), and the exhaust nozzle. The exhaust cone collects the exhaust gases discharged from the turbine section and gradually converts them into a solid flow of gases. In performing this, the velocity of the gases is decreased slightly and the pressure increased. This is due to the diverging passage between the outer duct and the inner cone; that is, the annular area between the two units increases rearward. The exhaust cone assembly consists of an outer shell or duct, an inner cone, three or four radial hollow struts or fins, and the necessary number of tie rods to aid the struts in supporting the inner cone from the outer duct.

The outer shell or duct is usually made of stainless steel and is attached to the rear flange of the turbine case. This element collects the exhaust gases and delivers them directly to the exhaust nozzle. The duct must be constructed to include such features as a predetermined number of thermocouple bosses for installing exhaust temperature thermocouples, and there must also be insertion holes for the supporting tie rods. In some cases, tie rods are not used for supporting the inner cone. If such is the case, the hollow struts provide the sole support of the inner cone, the struts being spot-welded in position to the inside surface of the duct and to the inner cone, respectively. [Figure 1-73] The radial struts actually have a twofold function. They not only support the inner cone in the

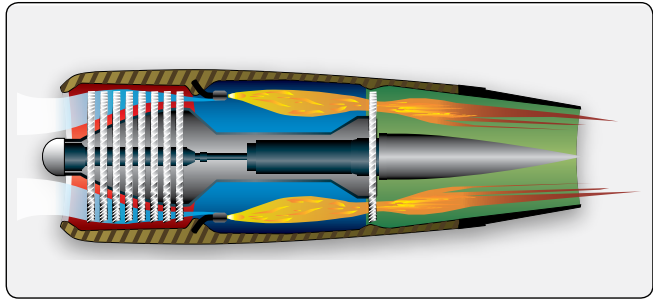

Figure 1-69. Single-stage rotor turbine.

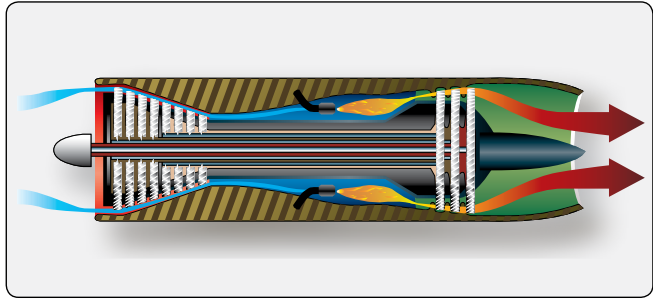

Figure 1-70. Multirotor turbine.

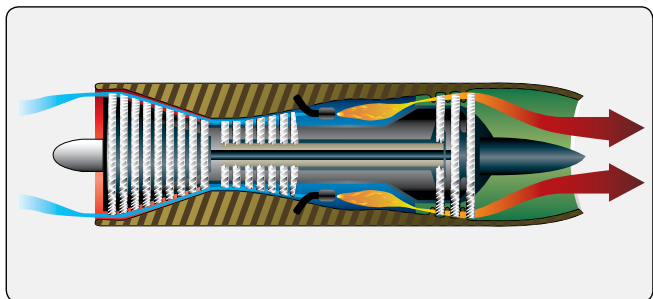

Figure 1-71. Dual-rotor turbine for split-spool compressor.

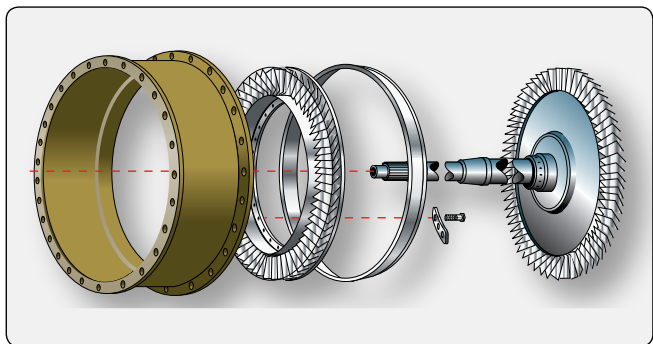

Figure 1-72. Turbine casing assembly.

exhaust duct, but they also perform the important function of straightening the swirling exhaust gases that would otherwise leave the turbine at an angle of approximately 45°.

The centrally located inner cone fits rather closely against the rear face of the turbine disc, preventing turbulence of the gases as they leave the turbine wheel. The cone is supported by the radial struts. In some configurations, a small hole is located in the exit tip of the cone. This hole allows cooling

air to be circulated from the aft end of the cone, where the pressure of the gases is relatively high, into the interior of the cone and consequently against the face of the turbine wheel. The flow of air is positive, since the air pressure at the turbine wheel is relatively low due to rotation of the wheel; thus, air circulation is assured. The gases used for cooling the turbine wheel return to the main path of flow by passing through the clearance between the turbine disc and the inner cone. The exhaust cone assembly is the terminating component of the basic engine. The remaining component (the exhaust nozzle) is usually considered an airframe component.

The tailpipe is usually constructed so that it is semiflexible. On some tailpipes, a bellows arrangement is incorporated in its construction, allowing movement in installation, maintenance, and in thermal expansion. This eliminates stress and warping which would otherwise be present.

The heat radiation from the exhaust cone and tailpipe could damage the airframe components surrounding these units. For this reason, some means of insulation had to be devised. There are several suitable methods of protecting the fuselage structure; two of the most common are insulation blankets and shrouds.

The insulation blanket, illustrated in *Figures 1-74 and 1-75*, consists of several layers of aluminum foil, each separated by a layer of fiberglass or some other suitable material. Although these blankets protect the fuselage from heat radiation, they are used primarily to reduce heat loss from the exhaust system. The reduction of heat loss improves engine performance.

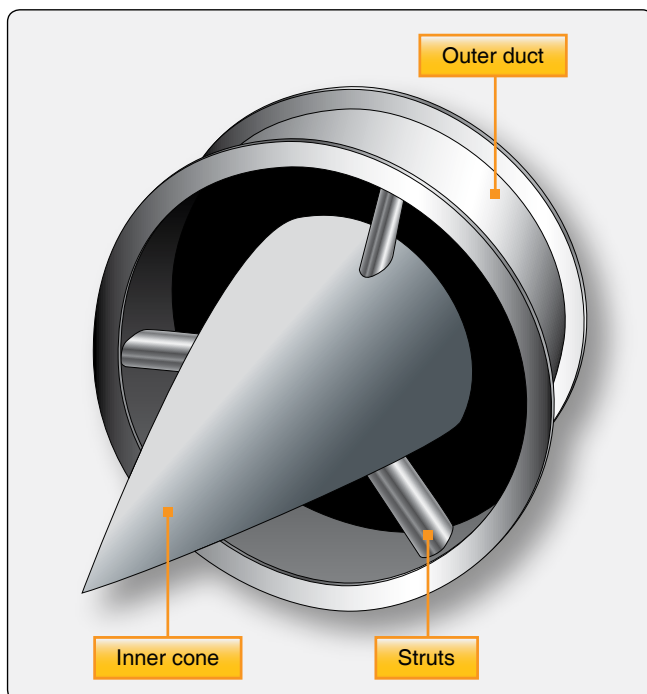

Figure 1-73. Exhaust collector with welded support struts.

There are two types of exhaust nozzle designs: the converging design for subsonic gas velocities and the converging-diverging design for supersonic gas velocities. These exhaust nozzle designs are discussed in greater detail in Chapter 3, Induction & Exhaust Systems.

The exhaust nozzle opening may be of either fixed or variable area. The fixed-area type is the simpler of the two exhaust nozzles since there are no moving parts. The outlet area of the fixed exhaust nozzle is very critical to engine performance. If the nozzle area is too large, thrust is wasted; if the area is too small, the engine could choke or stall. A variable-area exhaust nozzle is used when an augmentor or afterburner is used due to the increased mass of flow when the afterburner is activated. It must increase its open area when the afterburner is selected. When the afterburner is off, the exhaust nozzle closes to a smaller area of opening.

### Gas Turbine Engine Bearings & Seals

The main bearings have the critical function of supporting the main engine rotor. The number of bearings necessary for proper engine support is, for the most part, determined by the length and weight of the engine rotor. The length and weight are directly affected by the type of compressor used in the engine. Naturally, a two-spool compressor requires more bearing support. The minimum number of bearings required to support one shaft is one deep groove ball bearing (thrust and radial loads) and one straight roller bearing (radial load only). Sometimes, it is necessary to use more than one roller bearing if the shaft is subject to vibration or its length is excessive. The gas turbine rotors are supported by ball and roller bearings, which are antifriction bearings. [Figure 1-76] Many newer engines use hydraulic bearings, in which the outside race is surrounded by a thin film of oil. This reduces vibrations transmitted to the engine.

In general, antifriction bearings are preferred largely because they:

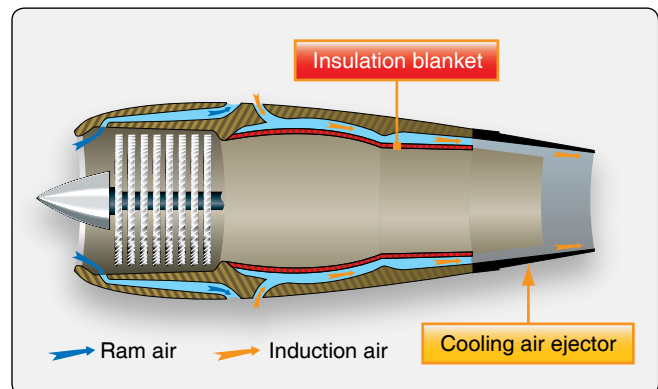
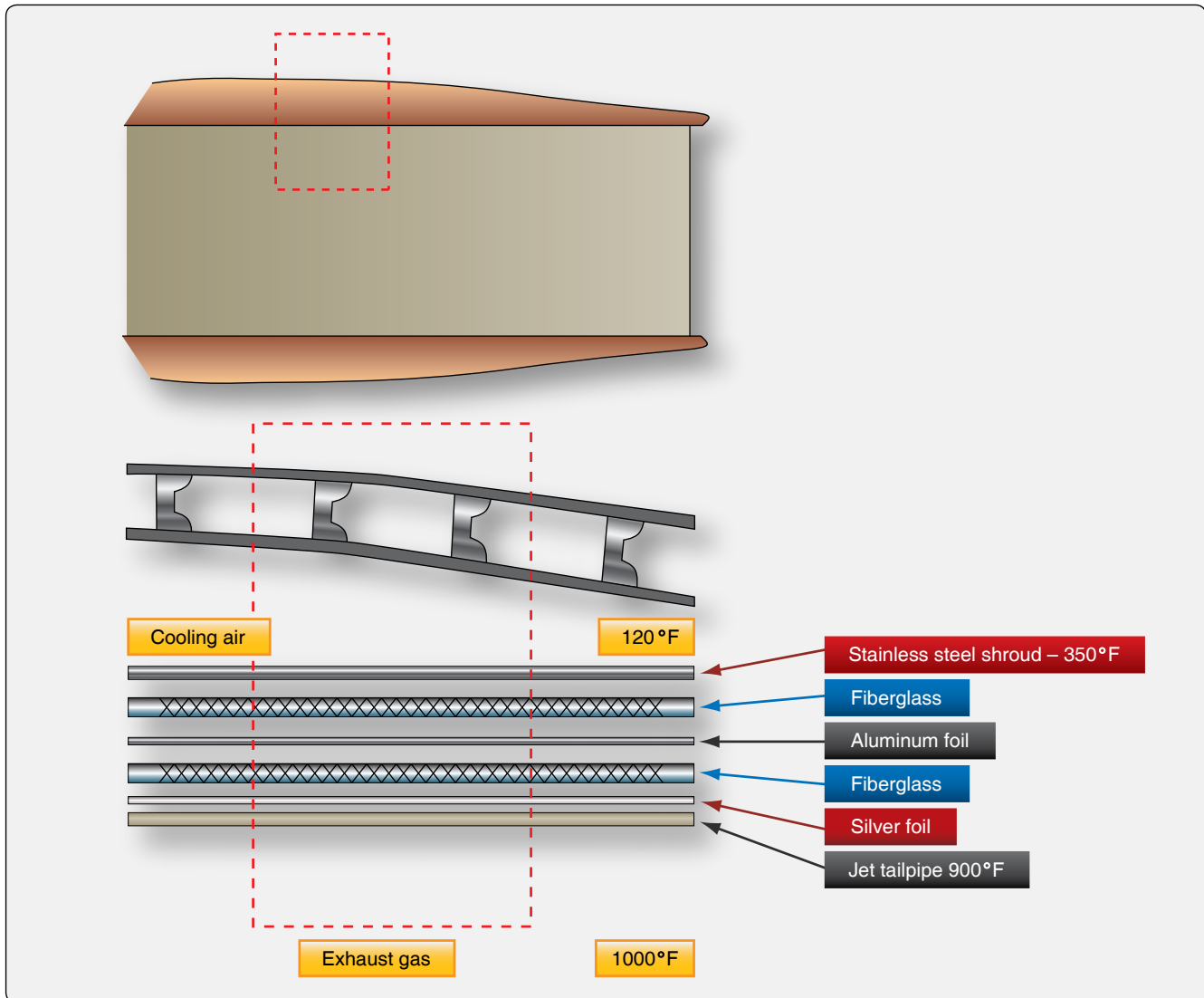

Figure 1-74. Exhaust system insulation blanket.



**Figure 1-75.** Insulation blanket with the temperatures obtained at the various locations shown.

- Offer little rotational resistance,
- Facilitate precision alignment of rotating elements,
- Are relatively inexpensive,
- Are easily replaced,
- Withstand high momentary overloads,
- Are simple to cool, lubricate, and maintain,
- Accommodate both radial and axial loads, and
- Are relatively resistant to elevated temperatures.

The main disadvantages are their vulnerability to foreign matter and tendency to fail without appreciable warning. Usually the ball bearings are positioned on the compressor or turbine shaft so that they can absorb any axial (thrust) loads or radial loads. Because the roller bearings present a larger working surface, they are better equipped to support radial loads than thrust loads. Therefore, they are used primarily

for this purpose. A typical ball or roller bearing assembly includes a bearing support housing, which must be strongly constructed and supported in order to carry the radial and axial loads of the rapidly rotating rotor. The bearing housing usually contains oil seals to prevent the oil leaking from its normal path of flow. It also delivers the oil to the bearing for its lubrication, usually through spray nozzles. The oil seals may be the labyrinth or thread (helical) type. These seals also may be pressurized to minimize oil leaking along the compressor shaft. The labyrinth seal is usually pressurized, but the helical seal depends solely on reverse threading to stop oil leakage. These two types of seals are very similar, differing only in thread size and the fact that the labyrinth seal is pressurized.

Another type of oil seal used on some of the later engines is the carbon seal. These seals are usually spring loaded and are similar in material and application to the carbon brushes

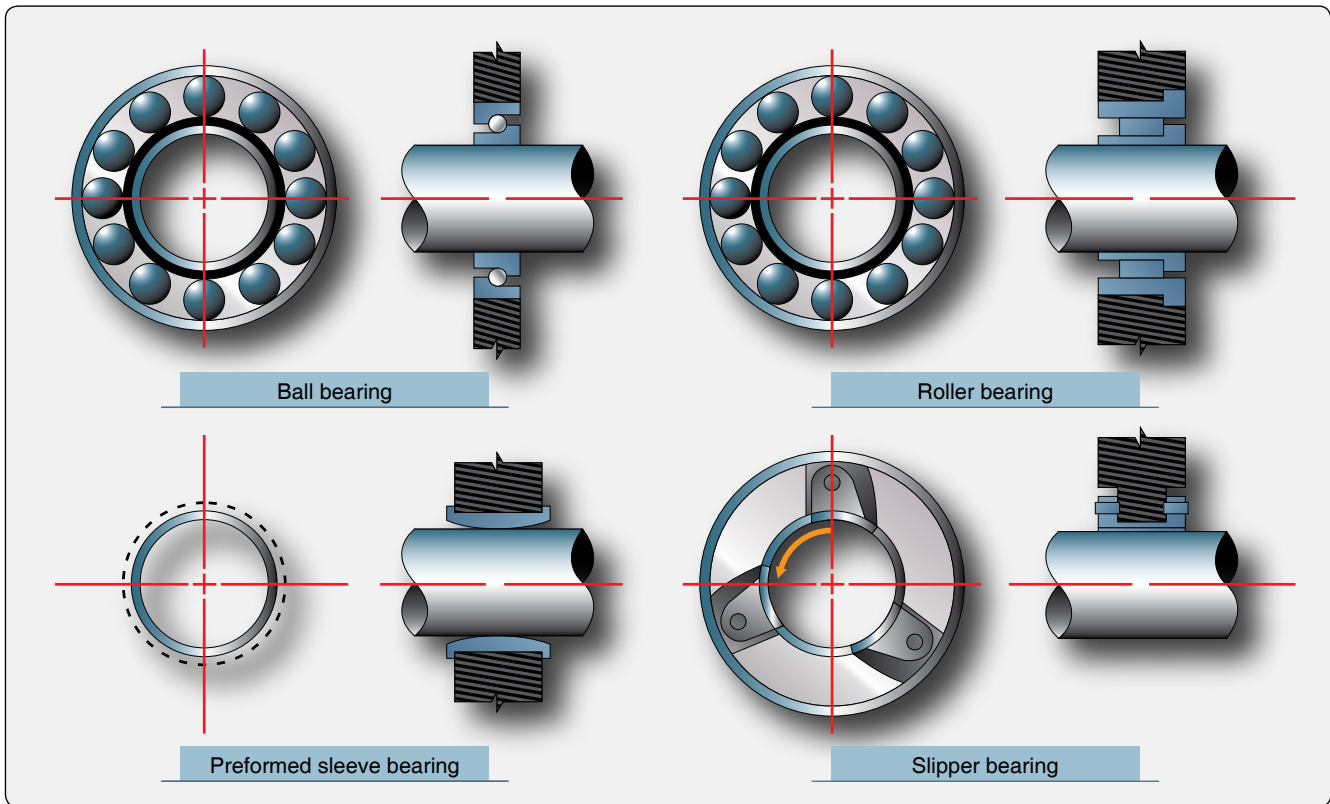

**Figure 1-76.** Types of main bearings used for gas turbine rotor support.

used in electrical motors. Carbon seals rest against a surface provided to create a sealed bearing cavity or void; thus, the oil is prevented from leaking out along the shaft into the compressor airflow or the turbine section. [Figure 1-77]

The ball or roller bearing is fitted into the bearing housing and may have a self-aligning feature. If a bearing is self-aligning, it is usually seated in a spherical ring. This allows the shaft a certain amount of radial movement without transmitting stress to the bearing inner race.

The bearing surface is usually provided by a machined journal on the appropriate shaft. The bearing is usually locked in position by a steel snap ring or other suitable locking device. The rotor shaft also provides the matching surface for the oil seals in the bearing housing. These machined surfaces are called lands and fit in rather close to the oil seal.

### Turboprop Engines

The turbopropeller (turboprop) engine is a combination of a gas turbine engine, reduction gear box, and a propeller. [Figure 1-78] Turboprops are basically gas turbine engines that have a compressor, combustion chamber(s), turbine, and an exhaust nozzle (gas generator), all of which operate in the same manner as any other gas engine. However, the difference is that the turbine in the turboprop engine usually has extra stages to extract energy to drive the propeller. In

addition to operating the compressor and accessories, the turboprop turbine transmits increased power forward through a shaft and a gear train to drive the propeller. The increased power is generated by the exhaust gases passing through additional stages of the turbine.

Some engines use a multirotor turbine with coaxial shafts for independent driving of the compressor and propeller. Although there are three turbines utilized in this illustration, as many as five turbine stages have been used for driving the two rotor elements, propeller, and accessories.

The exhaust gases also contribute to engine power output through thrust production, although the amount of energy available for thrust is considerably reduced. Two basic types of turboprop engine are in use: fixed turbine and free turbine. The fixed turbine has a mechanical connection from the gas generator (gas-turbine engine) to the reduction gear box and propeller. The free turbine has only an air link from gas generator to the power turbines. There is no mechanical link from the propeller to the gas turbine engine (gas generator). There are advantages and disadvantages of each system, with the airframe generally dictating the system used.

Since the basic components of normal gas-turbine and turboprop engines differ slightly only in design features, it should be fairly simple to apply acquired knowledge of the

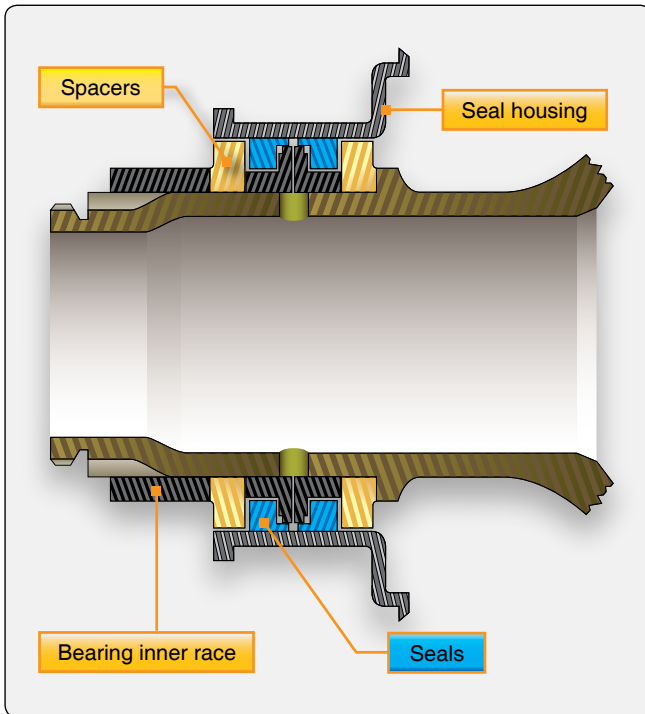

Figure 1-77. Carbon oil seal.

basic gas turbine to the turboprop.

The typical turboprop engine can be broken down into assemblies as follows:

1. The power section assembly—contains the usual major components of a gas turbine engine (i.e., compressor, combustion chamber, turbine, and exhaust sections).
2. The reduction gear or gearbox assembly—contains

those sections unique to turboprop configurations.

3. The torque meter assembly—transmits the torque from the engine to the gearbox of the reduction section.
4. The accessory drive housing assembly—mounted on the bottom of the compressor air inlet housing. It includes the necessary gear trains for driving all power section driven accessories at their proper rpm in relation to engine rpm.

### Turboshaft Engines

A gas-turbine engine that delivers power through a shaft to operate something other than a propeller is referred to as a turboshaft engine. [Figure 1-79] The output shaft may be coupled directly to the engine turbine, or the shaft may be driven by a turbine of its own (free turbine) located in the exhaust stream. As mentioned with the turboprop, the free turbine rotates independently. This principle is used extensively in current production of turboshaft engines. The turboshaft engine's output is measured in horsepower instead of thrust because the power output is a turning shaft.

### Turbofan Engines

The turbofan gas turbine engine is, in principle, the same as a turboprop, except that the propeller is replaced by a duct-enclosed axial-flow fan. [Figure 1-80] The fan can be a part of the first-stage compressor blades or can be mounted as a separate set of fan blades. The blades are mounted forward of the compressor.

The general principle of the fan engine is to convert more of the fuel energy into pressure. With more of the energy



Figure 1-78. PT6 turboprop engine.



**Figure 1-79.** Turboshaft engine.

converted to pressure, a greater product of pressure times area can be achieved. One of the major advantages is turbofan production of this additional thrust without increasing fuel flow. The end result is fuel economy with the consequent increase in range. Because more of the fuel energy is turned into pressure in the turbofan engine, additional stages must be added in the turbine section to provide the power to drive the fan. This means there is less energy left over and less thrust from the core exhaust gases. Also, in a mixed-exhaust nozzle (where fan air and core air mix in a common nozzle before entering ambient conditions) the exhaust nozzle must be larger in area. The result is that the fan develops most of the thrust. The thrust produced by the fan more than makes up for the decrease in thrust of the core (gas generator) of the engine. Depending on the fan design and bypass ratio, it produces 80 percent of the turbofan engine's total thrust.

Two different exhaust nozzle designs are used with turbofan engines. The air leaving the fan can be ducted overboard by a separate fan nozzle [Figure 1-43], or it can be ducted along the outer case of the basic engine to be discharged through the mixed nozzle (core and fan exhaust together). The fan air is either mixed with the exhaust gases before it is discharged (mixed or common nozzle), or it passes directly to the atmosphere without prior mixing (separate nozzle). Turbofans are the most widely used gas turbine engine for air transport aircraft. The turbofan is a compromise between the good

operating efficiency and high thrust capability of a turboprop and the high speed, high altitude capability of a turbojet.

### Turbine Engine Operating Principles

The principle used by a gas turbine engine as it provides force to move an airplane is based on Newton's Third Law. This law states that for every action there is an equal and opposite reaction; therefore, if the engine accelerates a mass of air (action), it applies a force on the aircraft (reaction). The turbofan generates thrust by giving a relatively slower acceleration to a large quantity of air. The old pure turbojet engine achieves thrust by imparting greater acceleration to a smaller quantity of air. This was its main problem with fuel consumption and noise.

The mass of air is accelerated within the engine by the use of a continuous-flow cycle. Ambient air enters the inlet diffuser where it is subjected to changes in temperature, pressure, and velocity due to ram effect. The compressor then increases pressure and temperature of the air mechanically. The air continues at constant pressure to the burner section where its temperature is increased by combustion of fuel. The energy is taken from the hot gas by expanding through a turbine which drives the compressor, and by expanding through an exhaust nozzle designed to discharge the exhaust gas at high velocity to produce thrust.

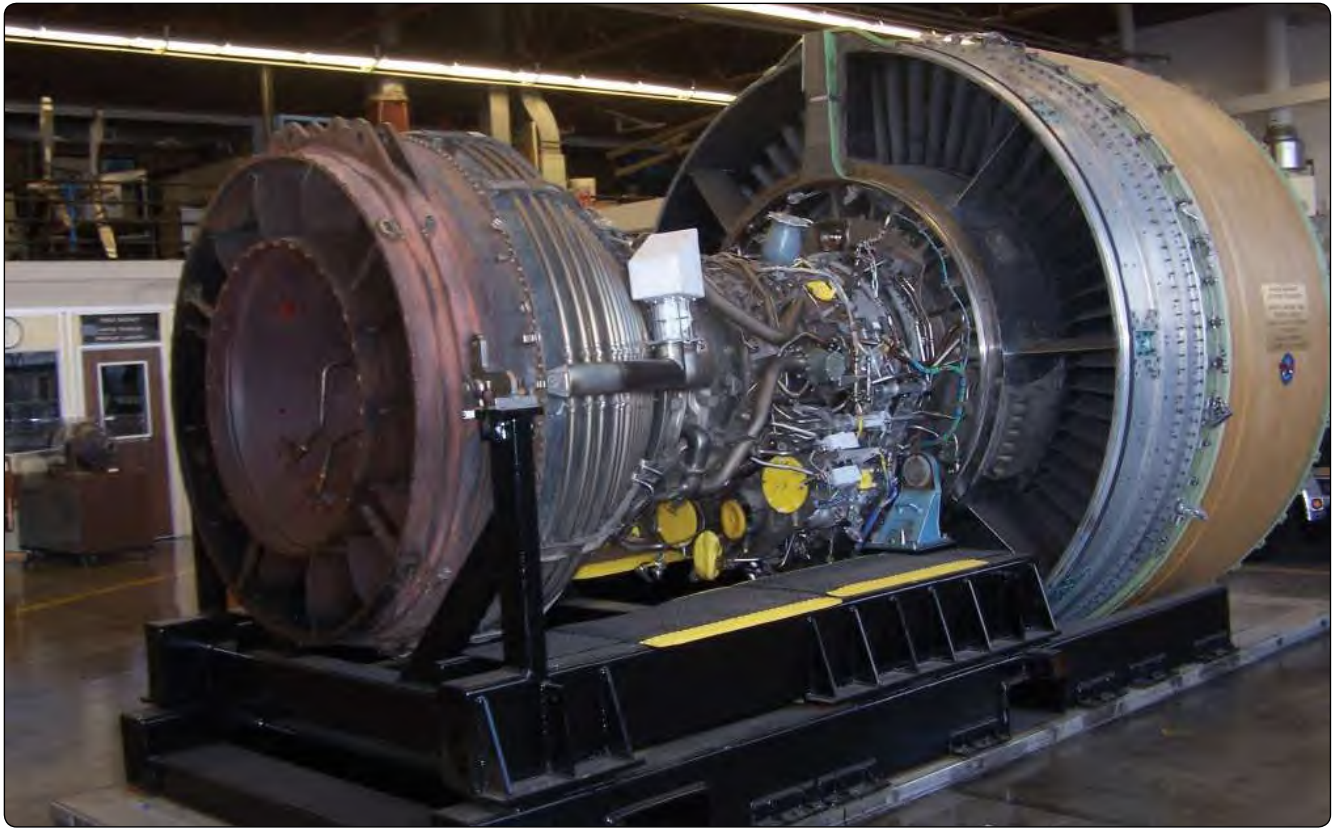

Figure 1-80. Turbofan engine.

The high velocity gases from the engine may be considered continuous, imparting this force against the aircraft in which it is installed, thereby producing thrust. The formula for thrust can be derived from Newton's second law, which states that force is proportional to the product of mass and acceleration. This law is expressed in the following formula:

$$F = M \times A$$

where:

F = force in pounds

M = mass in pounds per second

A = acceleration in feet per second

In the above formula, mass is similar to weight, but it is actually a different quantity. Mass refers to the quantity of matter, while weight refers to the pull of gravity on that quantity of matter. At sea level under standard conditions, 1 pound of mass has a weight of 1 pound. To calculate the acceleration of a given mass, the gravitational constant is used as a unit of comparison. The force of gravity is 32.2 feet per second squared (ft/sec<sup>2</sup>). This means that a free falling 1 pound object accelerates at the rate of 32.2 feet per second each second that gravity acts on it. Since the object mass weighs 1 pound, which is also the actual force imparted to it by gravity, it can be assumed that a force of 1 pound accelerates a 1 pound object at the rate of 32.2 ft/sec<sup>2</sup>.

Also, a force of 10 pound accelerates a mass of 10 pound at the rate of 32.2 ft/sec<sup>2</sup>. This is assuming there is no friction or other resistance to overcome. It is now apparent that the ratio of the force (in pounds) is to the mass (in pounds) as the acceleration in ft/sec<sup>2</sup> is to 32.2. Using M to represent the mass in pounds, the formula may be expressed thus:

$$\frac{F}{M} = \frac{A}{G} \text{ or } F = \frac{MA}{G}$$

where:

F = force

M = mass

A = acceleration

G = gravity

In any formula involving work, the time factor must be considered. It is convenient to have all time factors in equivalent units (i.e., seconds, minutes, or hours). In calculating jet thrust, the term "pounds of air per second" is convenient, since the second is the same unit of time used for the force of gravity.

**Thrust**

Using the following formula, compute the force necessary to accelerate a mass of 50 pounds by 100 ft/sec<sup>2</sup>.

$$F = \frac{MA}{G}$$

$$F = \frac{50 \text{ lb} \times 100 \text{ ft/sec}^2}{32.2 \text{ ft/sec}^2}$$

$$F = \frac{5,000 \text{ lb-ft/sec}^2}{32.2 \text{ ft/sec}^2}$$

$$F = 155 \text{ lb}$$

This illustrates that if the velocity mass per second is increased by 100, the resulting thrust is 155 pounds.

Since the turbojet engine accelerates air, the following formula can be used to determine jet thrust:

$$F = \frac{Ms (V_2 - V_1)}{G}$$

where:

F = force in pounds

Ms = mass flow in lb/sec

V<sub>1</sub> = inlet velocity

V<sub>2</sub> = jet velocity (exhaust)

V<sub>2</sub> - V<sub>1</sub> = change in velocity; difference between inlet velocity and jet velocity

G = acceleration of gravity or 32.2 ft/sec<sup>2</sup>

As an example, to use the formula for changing the velocity of 100 pounds of mass airflow per second from 600 ft/sec to 800 ft/sec, the formula can be applied as follows:

$$F = \frac{100 \text{ lb/sec} (800 \text{ ft/sec} - 600 \text{ ft/sec})}{32.2 \text{ ft/sec}^2}$$

$$F = \frac{20,000 \text{ lb/sec}}{32.2 \text{ ft/sec}^2}$$

$$F = 621 \text{ lb}$$

As shown by the formula, if the mass airflow per second and the difference in the velocity of the air from the intake to the exhaust are known, it is easy to compute the force necessary to produce the change in the velocity. Therefore, the thrust of the engine must be equal to the force required to accelerate the air mass through the engine. Then, by using the symbol “Fn” for thrust pounds, the formula becomes:

$$F_n = \frac{Ms (V_2 - V_1)}{G}$$

Thrust of a gas turbine engine can be increased by two methods: increasing the mass flow of air through the engine or increasing the gas velocity. If the velocity of the turbojet engine remains constant with respect to the aircraft, the thrust decreases if the speed of the aircraft is increased. This is because V<sub>1</sub> increases in value. This does not present a serious problem, however, because as the aircraft speed increases, more air enters the engine, and jet velocity increases. The resultant net thrust is almost constant with increased airspeed.

The Brayton cycle is the name given to the thermodynamic cycle of a gas turbine engine to produce thrust. This is a variable volume constant-pressure cycle of events and is commonly called the constant-pressure cycle. A more recent term is “continuous combustion cycle.” The four continuous and constant events are intake, compression, expansion (includes power), and exhaust. These cycles are discussed as they apply to a gas-turbine engine. In the intake cycle, air enters at ambient pressure and a constant volume. It leaves the intake at an increased pressure and a decrease in volume. At the compressor section, air is received from the intake at an increased pressure, slightly above ambient, and a slight decrease in volume. Air enters the compressor where it is compressed. It leaves the compressor with a large increase in pressure and decrease in volume, created by the mechanical action of the compressor. The next step, expansion, takes place in the combustion chamber by burning fuel, which expands the air by heating it. The pressure remains relatively constant, but a marked increase in volume takes place. The expanding gases move rearward through the turbine assembly and are converted from velocity energy to mechanical energy by the turbine. The exhaust section, which is a convergent duct, converts the expanding volume and decreasing pressure of the gases to a final high velocity. The force created inside the engine to keep this cycle continuous has an equal and opposite reaction (thrust) to move the aircraft forward.

Bernoulli’s principle (whenever a stream of any fluid has its velocity increased at a given point, the pressure of the stream at that point is less than the rest of the stream) is applied to gas turbine engines through the design of convergent and divergent air ducts. The convergent duct increases velocity and decreases pressure. The divergent duct decreases velocity and increases pressure. The convergent principle is usually used for the exhaust nozzle. The divergent principle is used in the compressor and diffuser where the air is slowing and pressurizing.

## Gas Turbine Engine Performance

Thermal efficiency is a prime factor in gas turbine performance. It is the ratio of net work produced by the engine to the chemical energy supplied in the form of fuel. The three most important factors affecting the thermal efficiency are turbine inlet temperature, compression ratio, and the component efficiencies of the compressor and turbine. Other factors that affect thermal efficiency are compressor inlet temperature and combustion efficiency. *Figure 1-81* shows the effect that changing compression ratio (compressor pressure ratio) has on thermal efficiency when compressor inlet temperature and the component efficiencies of the compressor and turbine remain constant. The effects that compressor and turbine component efficiencies have on thermal efficiency when turbine and compressor inlet temperatures remain constant are shown in *Figure 1-82*. In actual operation, the turbine engine exhaust temperature varies directly with turbine inlet temperature at a constant compression ratio.

Rpm is a direct measure of compression ratio; therefore, at constant rpm, maximum thermal efficiency can be obtained by maintaining the highest possible exhaust temperature. Since engine life is greatly reduced at high turbine inlet temperatures, the operator should not exceed the exhaust temperatures specified for continuous operation. *Figure 1-83* illustrates the effect of turbine inlet temperature on turbine blade life. In the previous discussion, it was assumed that the state of the air at the inlet to the compressor remains constant. Since this is a practical application of a turbine engine, it becomes necessary to analyze the effect of varying inlet conditions on the thrust or power produced. The three principal variables that affect inlet conditions are the speed of the aircraft, the altitude of the aircraft, and the ambient temperature. To make the analysis simpler, the combination of these three variables can be represented by a single variable called stagnation density.

The power produced by a turbine engine is proportional to the stagnation density at the inlet. The next three illustrations show how changing the density by varying altitude, airspeed, and outside air temperature affects the power level of the engine. *Figure 1-84* shows that the thrust output improves rapidly with a reduction in outside air temperature (OAT) at constant altitude, rpm, and airspeed. This increase occurs partly because the energy required per pound of airflow to drive the compressor varies directly with the temperature, leaving more energy to develop thrust. In addition, the thrust output increases since the air at reduced temperature has an increased density. The increase in density causes the mass flow through the engine to increase. The altitude effect on thrust, as shown in *Figure 1-85*, can also be discussed as a density and temperature effect. In this case, an increase in altitude causes a decrease in pressure and temperature.

Since the temperature lapse rate is lower than the pressure lapse rate as altitude is increased, the density is decreased. Although the decreased temperature increases thrust, the effect of decreased density more than offsets the effect of the colder temperature. The net result of increased altitude is a reduction in the thrust output.

The effect of airspeed on the thrust of a gas-turbine engine is shown in *Figure 1-86*. To explain the airspeed effect, it is necessary to understand first the effect of airspeed on the factors that combine to produce net thrust: specific thrust and engine airflow. Specific thrust is the net thrust in pounds developed per pound of airflow per second. It is the remainder of specific gross thrust minus specific ram drag. As airspeed is increased, ram drag increases rapidly. The exhaust velocity remains relatively constant; thus, the effect of the increase in

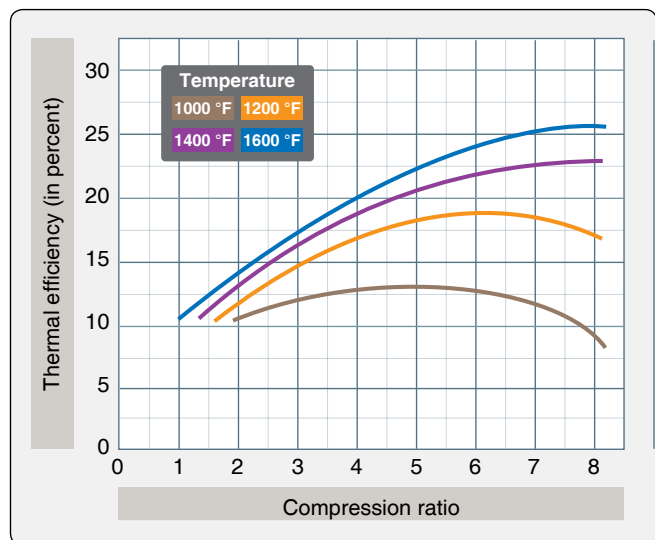

Figure 1-81. The effect of compression ratio on thermal efficiency.

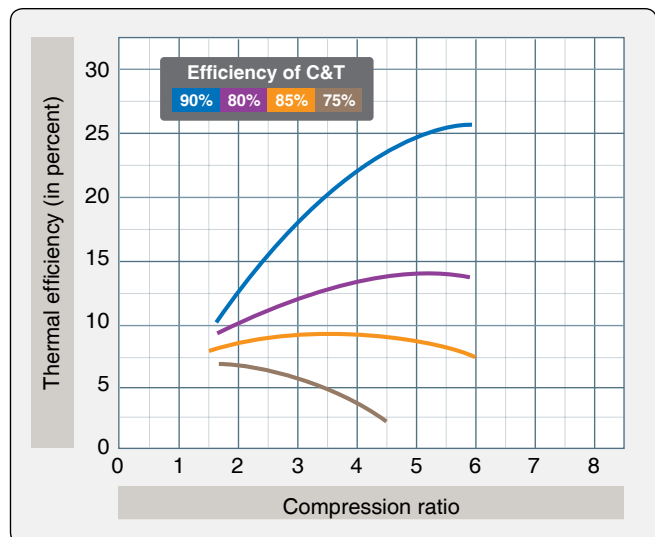
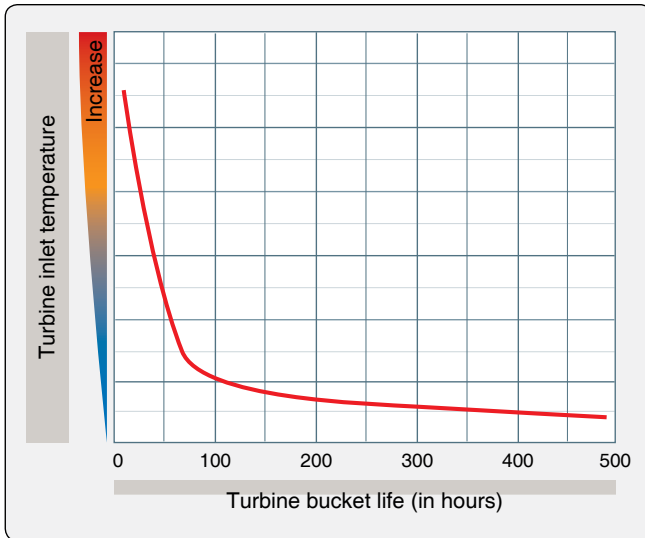
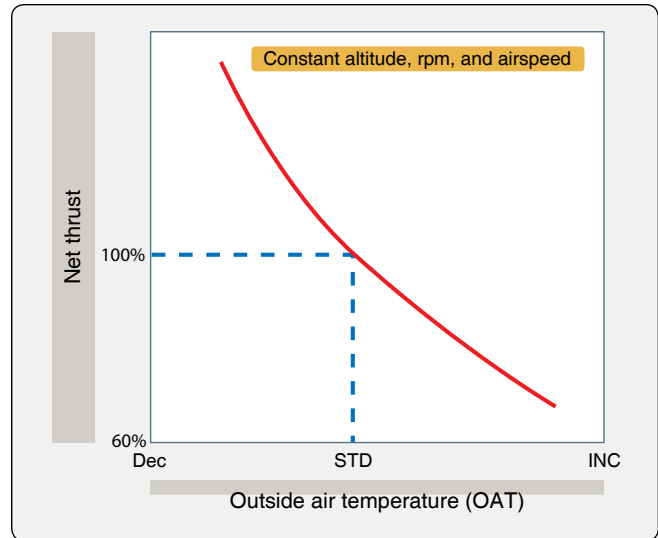

Figure 1-82. Turbine and compressor efficiency vs. thermal efficiency.



**Figure 1-83.** Effect of turbine inlet temperature on turbine bucket life.



**Figure 1-84.** Effect of OAT on thrust output.

airspeed results in decreased specific thrust. [Figure 1-86] In the low-speed range, the specific thrust decreases faster than the airflow increases and causes a decrease in net thrust. As the airspeed increases into the higher range, the airflow increases faster than the specific thrust decreases and causes the net thrust to increase until sonic velocity is reached. The effect of the combination on net thrust is illustrated in Figure 1-87.

**Ram Recovery**

A rise in pressure above existing outside atmospheric pressure at the engine inlet, as a result of the forward velocity of an aircraft, is referred to as ram pressure. Since any ram effect causes an increase in compressor entrance pressure over atmospheric, the resulting pressure rise causes an increase in the mass airflow and gas velocity, both of which tend to increase thrust. Although ram effect increases engine thrust, the thrust being produced by the engine decreases for a given throttle setting as the aircraft gains airspeed. Therefore, two opposing trends occur when an aircraft’s speed is increased. What actually takes place is the net result of these two different effects.

An engine’s thrust output temporarily decreases as aircraft speed increases from static, but soon ceases to decrease. Moving toward higher speeds, thrust output begins to increase again due to the increased pressure of ram recovery.

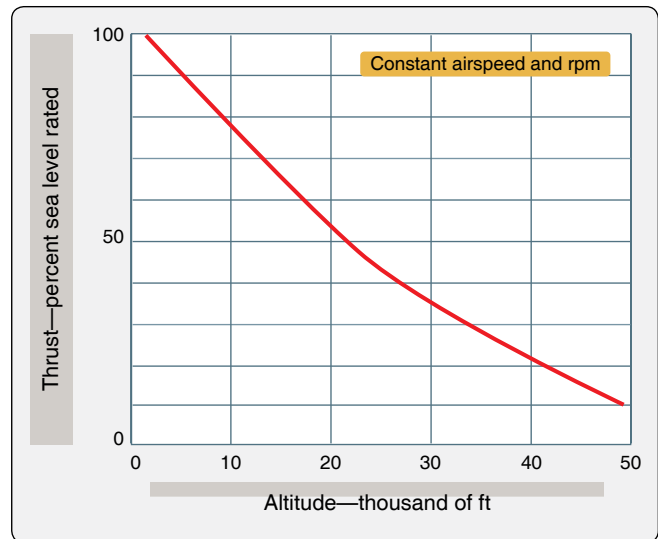

**Figure 1-85.** Effect of altitude on thrust output.

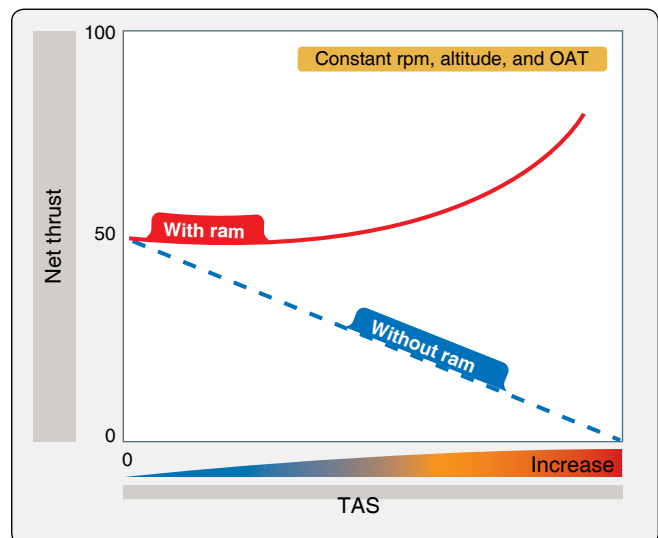

**Figure 1-86.** Effect of airspeed on net thrust.

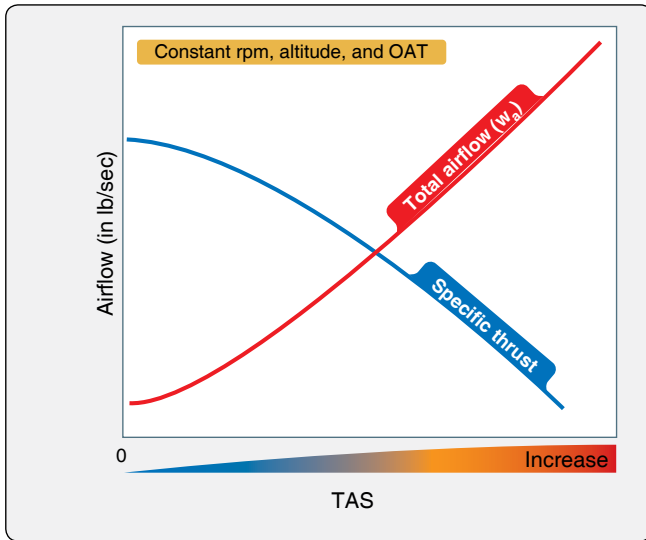

**Figure 1-87.** Effect of airspeed on specific thrust and total engine airflow.